



Eagle and Eaglet Baseboard for Toradex Apalis ARM Modules

Revision	Date	Comment
1.0	07/07/2016	Initial Release
1.1	08/08/2016	Updated as per the feedback
1.2	11/12/2016	Updated for Eagle Rev A changes
1.3	01/08/2016	Updated SW related information
1.4	24/03/2017	Updated for production release
1.5	22/06/2017	Updated steps to flash image from SD card

**FOR TECHNICAL SUPPORT
PLEASE CONTACT:**

support@diamondsystems.com

Copyright 2017
Diamond Systems Corporation
www.diamondsystems.com

CONTENTS

1	Important Safe Handling Information	4
2	Introduction	6
2.1	Available Models	6
2.2	Features.....	6
2.2.1	Eagle Features.....	6
2.2.2	Eaglet Features	7
2.3	Operating System Support	8
2.4	Mechanical, Electrical, Environmental	8
2.5	Customization Options	8
2.5.1	Eagle Customization	8
2.5.2	Eaglet Customization	8
2.6	Feature support Limitations of Eagle and Eaglet Board with Toradex Apalis Modules:	9
3	Functional Block Diagram	11
3.1	Eaglet	11
3.2	Eagle	12
3.3	Feature Descriptions	13
3.3.1	Processor Features	13
3.3.2	Ethernet	13
3.3.3	USB.....	13
3.3.4	PCIe	15
3.3.5	mSATA.....	16
3.3.6	Micro SD (MMC)	16
3.3.7	Display.....	16
3.3.8	Audio.....	16
3.3.9	Serial Ports.....	16
3.3.10	GPIO	17
3.3.11	Analog Input	17
3.3.12	CAN	17
3.3.13	Serial Camera.....	17
3.3.14	Type Specific Mezzanine.....	17
3.3.15	LED Indicators	17
3.3.16	Real-Time Clock (RTC).....	18
3.3.17	Power Supply	18
4	Mechanical BOARD DRAWING	19
4.1	Eaglet Baseboard.....	19
4.2	Eagle Baseboard	20
5	Board Layout (Connector and Jumper Locations)	21
5.1	Eagle Baseboard	21
5.2	Eaglet Baseboard.....	24
5.2.1	I/O Connectors, Jumpers and LED Summary for Eaglet	25
6	IO Connectors	26
6.1	Connector Pin-out and Signal Description	26
6.1.1	Eaglet and Eagle Baseboard.....	26
6.1.2	Eagle Baseboard	35
6.2	List of Connectors.....	39
6.2.1	Eaglet Baseboard	39
6.2.2	Eagle Baseboard	40
7	I/O Cables	41
7.1	Eagle Baseboard	41
7.2	Eaglet Baseboard.....	42

8	Jumper Description	43
8.1	LVDS VCC, Backlight & RTC (JP1)	44
8.2	USB OTG & RS422/RS485 Terminations (JP2)	45
9	Getting Started	46
9.1	Development Kit.....	46
9.2	Quick Setup	46
9.3	Booting	47
9.3.1	Updating Software Image from SD card [for systems with U boot available].....	47
10	Start-up scripts	51
11	Display Features	51
11.1	VGA.....	51
11.2	HDMI.....	51
11.3	LVDS.....	52
11.3.1	LCD Backlight	52
11.4	Dual Display	53
11.5	USB Interface.....	54
12	Serial Ports and System Console	55
12.1	Configuration.....	55
12.2	System Console	56
12.3	Serial port numbers.....	57
12.4	UART configuration GPIO details for RS232/422/485 modes	58
12.4.1	Apalis UART ports	58
12.4.2	Exar UART Ports	58
13	Utility connector features	59
13.1	I2C and PWM	59
14	DAQ Architecture overview	60
14.1	Analog input	60
14.2	PWM	60
14.3	GPIO.....	60
14.3.1	GPIOs form Apalis Module.....	60
14.3.2	GPIOs using I2C GPIO expander.....	60
15	Type-specific I/O Expansion	65
16	Programming I2C	65
17	Factory reset and Recovering MAC address	65
18	Panel IO	66
19	CAN Add-on Module	67
19.1	GPIO LIBRARY API	69
20	Appendix	71
20.1	Appendix – 1 Compiling Custom Applications.....	71
20.2	Appendix – 2 Inserting COM Module	71
20.2.1	Assembly procedure	72

1 Important Safe Handling Information



WARNING!

ESD-Sensitive Electronic Equipment

Observe ESD-safe handling procedures when working with this product. Always use this product in a properly grounded work area and wear appropriate ESD-preventive clothing and/or accessories. Always store this product in ESD-protective packaging when not in use.

Safe Handling Precautions

The Eagle baseboard contains a high number of I/O connectors with connection to sensitive electronic components. This creates many opportunities for accidental damage during handling, installation and connection to other equipment. The list here describes common causes of failure found on boards returned to Diamond Systems for repair. This information is provided as a source of advice to help you prevent damaging your Diamond (or any vendor's) embedded computer boards.

ESD damage – This type of damage is usually almost impossible to detect, because there is no visual sign of failure or damage. The symptom is that the board eventually simply stops working, because some component becomes defective. Usually the failure can be identified and the chip can be replaced.

To prevent ESD damage, always follow proper ESD-prevention practices when handling computer boards.

Damage during handling or storage – On some boards we have noticed physical damage from mishandling. A common observation is that a screwdriver slipped while installing the board, causing a gouge in the PCB surface and cutting signal traces or damaging components.

Another common observation is damaged board corners, indicating the board was dropped. This may or may not cause damage to the circuitry, depending on what is near the corner. Most of our boards are designed with at least 25 mils clearance between the board edge and any component pad, and ground / power planes are at least 20 mils from the edge to avoid possible shorting from this type of damage. However, these design rules are not sufficient to prevent damage in all situations.

A third cause of failure is when a metal screwdriver tip slips, or a screw drops onto the board while it is powered on, causing a short between a power pin and a signal pin on a component. This can cause overvoltage / power supply problems described below. To avoid this type of failure, only perform assembly operations when the system is powered off.

Sometimes boards are stored in racks with slots that grip the edge of the board. This is a common practice for board manufacturers. However, our boards are generally very dense, and if the board has components very close to the board edge, they can be damaged or even knocked off the board when the board tilts back in the rack. Diamond recommends that all our boards be stored only in individual ESD-safe packaging. If multiple boards are stored together, they should be contained in bins with dividers between boards. Do not pile boards on top of each other or cram too many boards into a small location. This can cause damage to connector pins or fragile components.

Power supply wired backwards – Our power supplies and boards are not designed to withstand a reverse power supply connection. This will destroy each IC that is connected to the power supply (i.e. almost all ICs). In this case the board will most likely will be unrepairable and must be replaced. A chip destroyed by reverse power or by excessive power will often have a visible hole on the top or show some deformation on the top surface due to vaporization inside the package. **Check twice before applying power!**

Bent connector pins – This type of problem is often only a cosmetic issue and is easily fixed by bending the pins back to their proper shape one at a time with needle-nose pliers. The most common cause of bent connector pins is when a PC/104 board is pulled off the stack by rocking it back and forth left to right, from one end of the connector to the other. As the board is rocked back and forth it pulls out suddenly, and the pins at the end get bent significantly. The same situation can occur when pulling a ribbon cable off of a pin header. If the pins are

bent too severely, bending them back can cause them to weaken unacceptably or even break, and the connector must be replaced.

2 Introduction

Eagle is a 3.5-inch form factor baseboard compatible with the Toradex Apalis family of ARM COMs, including Freescale i.MX6, Nvidia Tegra 3 (T30), and Nvidia Tegra K1 (TK1) processors.

Eaglet is a low cost version of Eagle, with 4"x4" form factor. Eaglet features basic interfaces supported by the Apalis module.

2.1 Available Models

Model	Eaglet	Eagle
PCB size	4"x4"	5.75"x4" (3.5" Form factor SBC)
Serial ports	2x Multiprotocol ⁽¹⁾ 2x RS232 Only	8x Multiprotocol ⁽¹⁾
USB2.0 ⁽²⁾	2	4
USB3.0 ⁽²⁾	2	2
Input voltage	5V	9-36V
Gigabit Ethernet Port	1	2
GPIO	8	16
Opto GPIO	-	4 in + 4 out
Type specific connector	-	1
CSI	-	1
Micro module expansion (CAN, I2C, SPI)	Yes	Yes

(1) RS232/RS422/RS485.

(2) USB3.0 is supported for TK1 module only. With other ARM modules, USB2.0 interface are available on the same USB3.0 header. Refer Section 11.5 for USB ports availability based on the ARM variant.

2.2 Features

2.2.1 Eagle Features

- ◆ 5-6x USB 2.0, 2x USB 3.0 port (TK1 model only); 1 port supports OTG
- ◆ 2x Ethernet (10/100/1000 Mbps)
- ◆ 1x SD/MMC 4-Bit
- ◆ 1x mSATA socket
- ◆ Mini PCIe socket
- ◆ Analog VGA interface
- ◆ Dual channel LVDS interface (up to 24-bit color)
- ◆ HDMI port
- ◆ Analogue audio I/O
- ◆ 8x RS-232/422/485 serial ports
- ◆ 4x PWM (3 customer-accessible + 1 LCD Backlight control)
- ◆ 4x 12-bit Analog inputs
- ◆ 2x CAN 2.0B ports (up to 1Mbit/s) using optional daughterboard
- ◆ Real-time clock with battery backup
- ◆ 16x GPIO (3.3V)
- ◆ 4x Opto-isolated Digital Inputs and 4x Opto-isolated Digital Outputs
- ◆ Resistive touch screen connector 4/5-wire
- ◆ 3x I2C

- ◆ 2x SPI
- ◆ 1x S/PDIF In/Out
- ◆ CSI Camera Interface
- ◆ Type Specific Board Connector

2.2.2 Eaglet Features

- ◆ 2x USB 2.0, 2x USB 3.0 port (one OTG supported port)
- ◆ 1x RJ45 Ethernet (10/100/1000 Mbit)
- ◆ 1x SD/MMC 4 Bit
- ◆ 1x mSATA socket
- ◆ Mini PCIe socket
- ◆ Analog VGA interface
- ◆ Dual channel LVDS interface (up to 24-bit color)
- ◆ HDMI port
- ◆ Analog audio I/O
- ◆ 1x S/PDIF In/Out
- ◆ 4x RS-232/422/485 Serial Interfaces
- ◆ 4x PWM (3 customer-accessible + 1 LCD Backlight control)
- ◆ 4x Analog inputs
- ◆ 2x CAN 2.0B Interface (up to 1Mbit/s) using optional daughterboard
- ◆ Real-time clock with battery backup
- ◆ 8xDigital GPIOs (3.3V)
- ◆ Resistive touch screen connector 4/5-wire
- ◆ 3x I2C
- ◆ 2x SPI

2.3 Operating System Support

- ◆ Linux

2.4 Mechanical, Electrical, Environmental

- ◆ Form factor: Eagle: 3.5" form factor, 146 x 102mm / 5.7" x 4.0"
Eaglet: 4.0" x 4.0" / 102 x 102mm
- ◆ Cooling : Apalis heat sink is installed for wide temperature operation
- ◆ Power input: Eagle: +9VDC to +36VDC
Eaglet: +5VDC +/-5%
- ◆ Operating Temp: -40°C to +85°C ambient (depending on the model of COM installed)

2.5 Customization Options

The following customization options are available for the Eagle Baseboard. Minimum order quantities may apply for customization. Contact Diamond Systems sales or [support](#) for further information

2.5.1 Eagle Customization

- ◆ Opto isolation for Serial port 5 to Serial port 8.
- ◆ 1.8V high speed SD mode
- ◆ Replace configuration jumpers with 0 ohm resistors
- ◆ Lower Cost RS232 only serial protocol
- ◆ Low cost non opto I2C expander GPIOs

2.5.2 Eaglet Customization

- ◆ 4 USB2.0 ports
- ◆ Multi-functional serial ports
- ◆ SIM Card holder for 3G/4G module
- ◆ Support for +9V to +36V wide input

2.6 Feature support Limitations of Eagle and Eaglet Board with Toradex Apalis Modules:

Diamond Systems Eagle Carrier Board support with Toradex Apalis COM Modules							
S.NO	Feature	I.MX6 COM (NXP)		TK1 COM (Nvidia Tegra)		T30 COM (Nvidia Tegra)	
1	Display						
a	VGA	YES	Tested up to 1024x768M resolution. The resolution depends on the VGA DAC used in the COM module. Resolution support varies with different COM module configuration from Toradex.	NO	Feature not supported by Nvidia SOC	NO	Not Supported by Toradex
b	HDMI	YES	Supports up to Full HD 1920x1080M resolution	YES	Supports up to Full HD 1920x1080M resolution	YES	Supports up to Full HD 1920x1080M resolution
c	LVDS	YES	Supports up to Full HD 1920x1080M resolution	YES	Supports only fixed resolutions such as 800x600, 1024x600, 1366x768	YES	Supports up to Full HD 1920x1080M resolution
2	Audio						
a	Audio Out	YES	Can Play back audio to Head phones with 3.5mm Jack	YES	Can Play back audio to Head phones with 3.5mm Jack	YES	Can Play back audio to Head phones with 3.5mm Jack
b	Line In	YES	Can record audio from Phones/Tablet using 3.5mm Aux cable	YES	Can record audio from Phones/Tablet using 3.5mm Aux cable	YES	Can record audio from Phones/Tablet using 3.5mm Aux cable
c	Mic In	YES	Can be used with PC Head phone having dedicated Mic input 3.5mm jack and tested OK.	YES	Can be used with PC Head phone having dedicated Mic input 3.5mm jack and tested OK.	YES	Can be used with PC Head phone having dedicated Mic input 3.5mm jack and tested OK.
3	USB						
a	USB3.0 Ports	NO	I.MX6 SOC does not support USB3.0 ports	YES	Supports 2 Nos. of ports and tested OK.	NO	Tegra T30 SOC does not support USB3.0 ports
b	USB2.0 Ports	YES	Totally 6 USB2.0 ports available in Eagle board and supports mass storage & IO devices	YES	Totally 4 USB2.0 ports available and supports mass storage & IO devices	YES	Totally 5 USB2.0 ports available in Eagle board and supports mass storage & IO devices
4	Serial Ports						
a	From Apalis Module UART Ports 1 to 4	YES	All ports supports RS232, RS422, RS485 protocol modes operation	YES* *Refer Remarks	Except UART Pot1, all ports support RS232, RS422, RS485 protocol modes operation	YES	All ports support RS232, RS422, RS485 protocol modes operation

					UART Port1 supports only RS232 mode.		
b	From Exar chip- XR17V354 (PCIe to UART converter On Eagle Board) EXAR Ports 5 to 8	YES	All ports support RS232, RS422, RS485 protocol modes operation.	NO* *Refer Remarks	Current release does not support these ports.	NO* *Refer Remarks	Current release does not support these ports.
5	10/100/1G Ethernet	YES	Supports 2 Ports	YES	Supports 2 Ports	YES	Supports 2 Ports
6	MAC Address Programming	YES	Through Linux commands	YES	Through Linux commands	YES*	Only Ethernet Port1 supports. Port2 MAC address programming is not supported in this release
7	GPIO						
a	From Apalis COM module – 8 Nos.	YES	Supported	YES	Supported	YES* *Refer Remarks	7 GPIOs supported. GPIO7 is exception. It is used for PCIE Reset Signaling purpose.
b	From I2C to GPIO Expander – 8 Nos.	YES	Supported	YES	Supported	YES	Supported
c	Optical Isolated – 4 Input & 4 Output	YES	Supported	YES	Supported	YES	Supported
8	Mini PCIe – Daughter Card Interface	YES	Supported	YES	Supported	YES	Supported
9	Mini SATA – Daughter Card Interface	YES	Supported	YES	Supported	YES	Supported
10	MMC/ Micro SD Interface	YES	Supported	YES	Supported	YES	Supported
11	PWM Output	YES	Supported	YES	Supported	YES	Supported
12	Analog Input	YES	Supported	YES* *Refer Remarks	Supported *ADC output value must be multiplied by scale of (0.05) and divided by 1000 to get the actual output.	YES	Supported
13	CAN Interface	YES	Supported	NO* *Refer Remarks	Currently Toradex software does not support CAN interface. Once support provided by them, it has to be incorporated in Eagle board firmware and to be tested.	YES	Supported

3 Functional Block Diagram

3.1 Eaglet

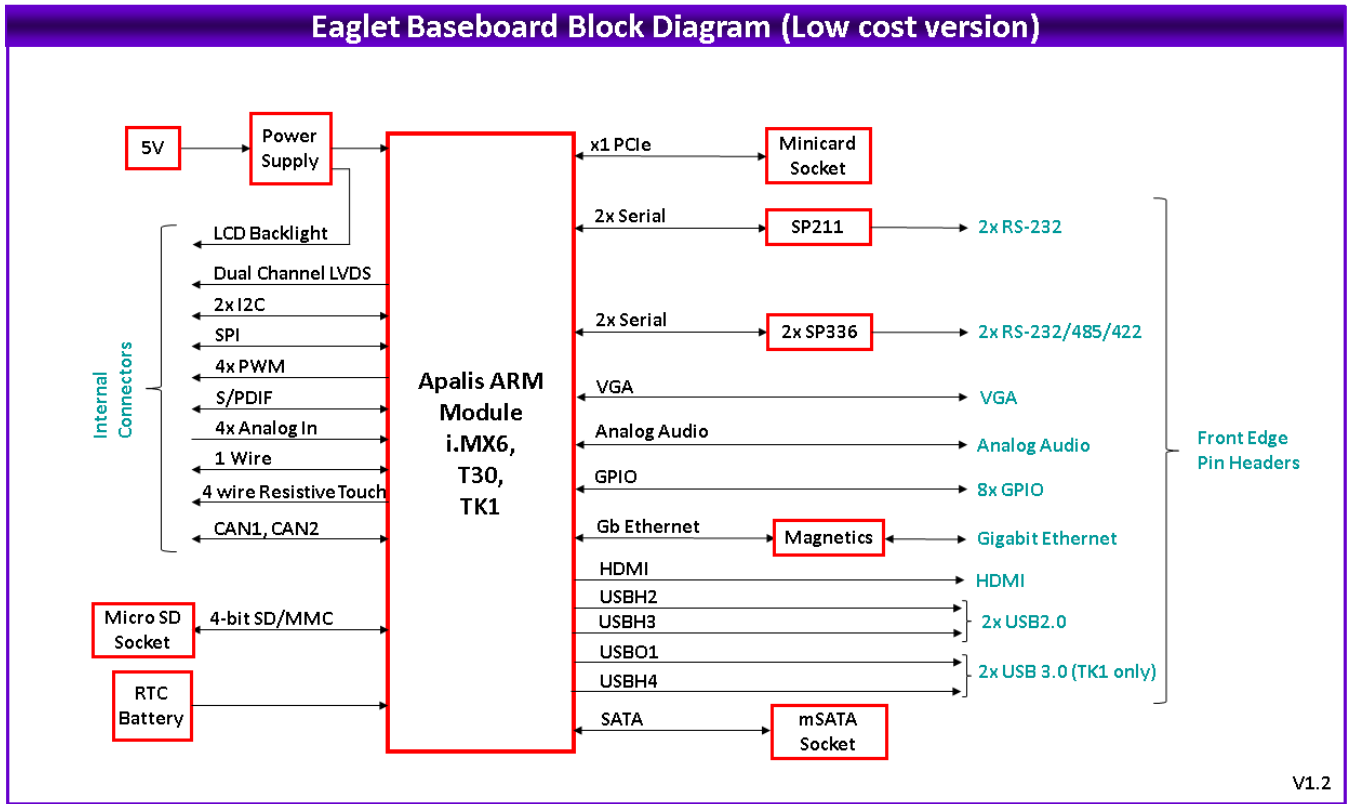

Figure 1 Functional Block Diagram of Eaglet

3.2 Eagle

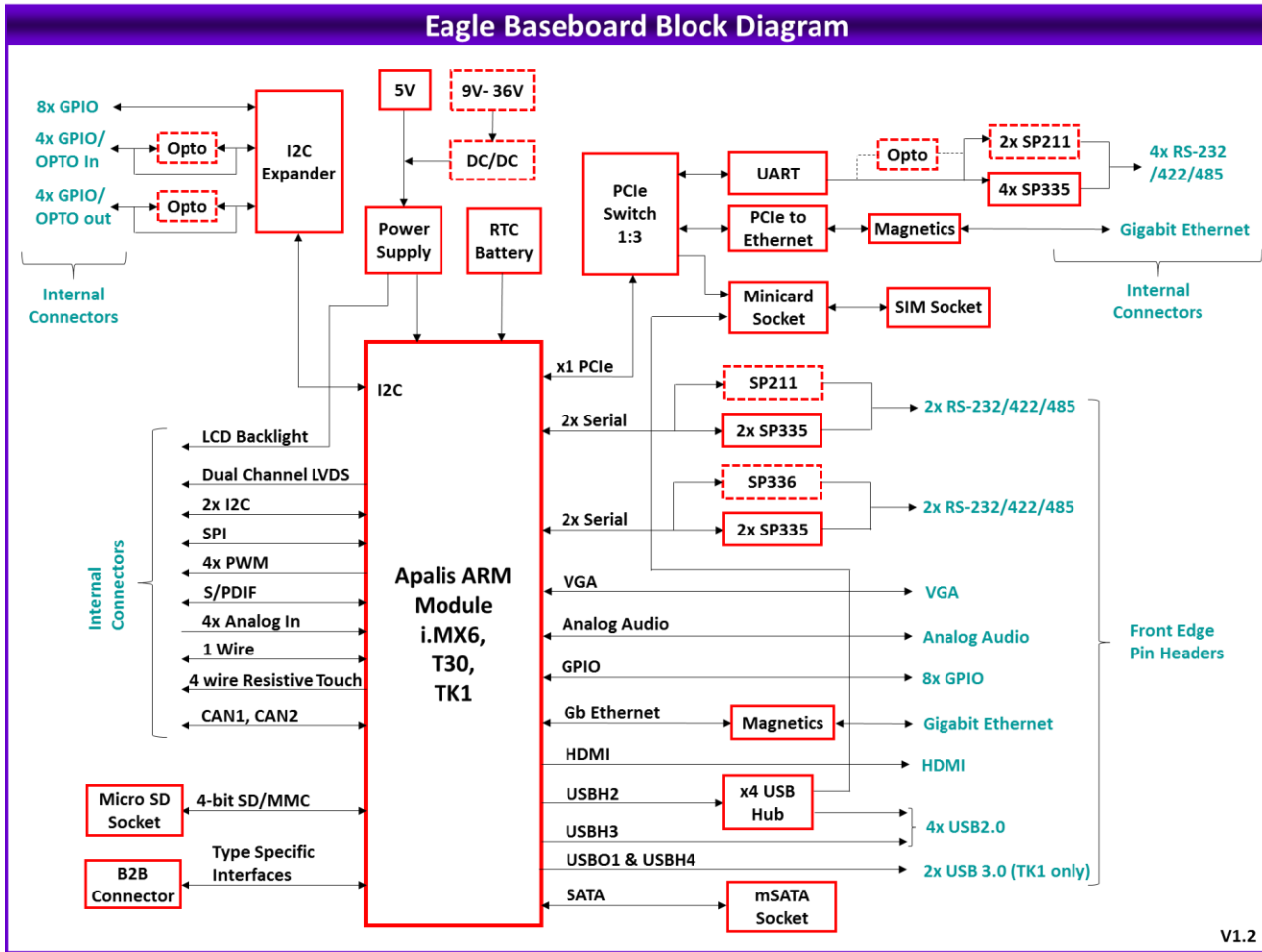

Figure 2 Functional Block Diagram of Eagle

3.3 Feature Descriptions

This section describes the key subsystems of both Eagle and Eaglet baseboard

3.3.1 Processor Features

Eagle baseboard supports 3 types of Toradex Apalis family of ARM COMs, including Freescale i.MX6, Nvidia Tegra T30, and Nvidia TK1 processors. Following Table provides the brief features of the ARM processor modules.

Feature	T30	i.MX6	TK1
COM	NVIDIA Tegra 3, quad ARM A9, up to 1.4GHz	Freescale i.MX6, dual/quad ARM A9, up to 1.0GHz	NVIDIA Tegra K1 quad-core Cortex-A15, up to 2.2GHz
Memory	1GB/2GB DDR3L built into module	512MB/1GB/2GB DDR3 built into module	2GB DDR3L built into module
Flash	4GB/8GB eMMC built into module	4GB eMMC built into module	16GB eMMC built into module

For detailed information about Apalis ARM product family visit [Toradex website](#)

3.3.2 Ethernet

The Eagle provides two Ethernet ports. One is a 10/100/1000 Ethernet port directly from the Apalis module. Ethernet connection is via a pin header, with necessary magnetics on the board. Ethernet is connected to RJ45 connector with Magnetics on a [Panel IO](#) board. On board LEDs are provided for Link and Activity indication near the Ethernet header (**J13**).

The second is a 10/100/1000Mbps Ethernet port realized using an Intel I210IT PCIe Gigabit Ethernet Controller (MAC + PHY). Ethernet connection is via a pin header (**J23**) with necessary magnetics on the board. The connector (**J23**) provides access to LED signals

Primary Ethernet port is available on both Eagle and Eaglet baseboard. Secondary Ethernet is available only in Eagle full feature baseboard.

3.3.3 USB

The Eagle provides 2x USB3.0 ports coming directly from Apalis module and available on the standard USB3.0 20 pin header (**J17**).

Eagle has 4x USB 2.0 Host interface via a header. One of these (USBH3) directly comes from Apalis module and available on the 2x5 header (**J12**).

USBH2 port from Apalis module is connected to a 4 port USB hub from SMSC (USB2514). Three of these are available on 2x5 Headers (**J12 and J16**), and fourth port is connected to the mini PCIe socket.

USB 2.0 ports on Header **J12** are available at stacked USB2.0 header on Panel IO Board.

Refer **Figure 3** for USB interface block diagram for Eagle baseboard.

USB01 on USB3.0 header (**J17**) supports OTG. By using jumper JP2 Pins 1-2-3, it is possible to configure USB01 port either as Peripheral or as a Host interface.

Caution: While using USB01 in peripheral mode special attention should be given to ensure if the jumper JP2 is set for peripheral mode (Pins 1-2). USB Type A to Type A cable should not be used as it may cause damage to the circuitry of Eagle or the external device connected.

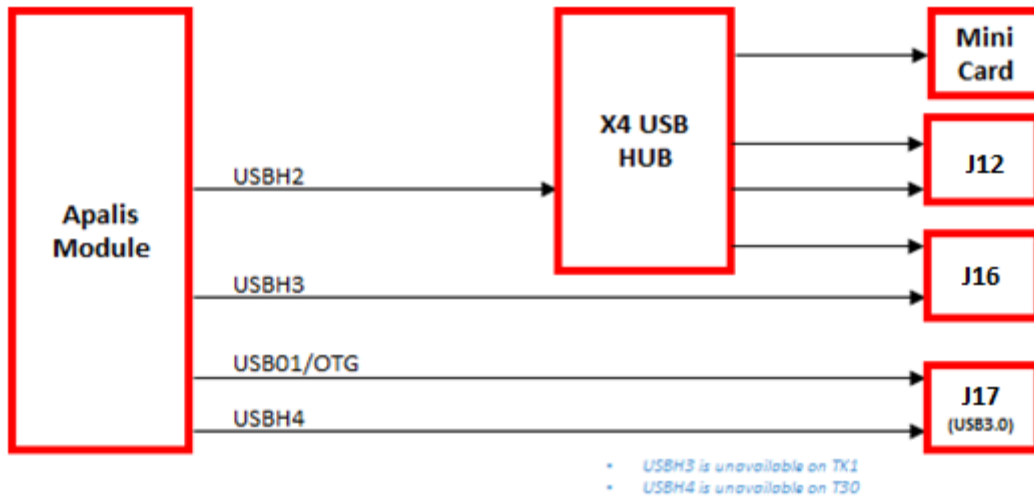

Figure 3 USB Signal connection for Eagle baseboard



Figure 4 USB Signal connection for Eaglet baseboard

3.3.4 PCIe

Eagle baseboard features 4 port PCI Express Gen2 Switch from PLX. It is used to connect the standard PCIe interface on the Eagle baseboard to PCIe to UART, PCIe to Ethernet and mini PCIe slot (J29).

Eagle baseboard supports both half sized and full sized mini PCIe cards.

For low cost Eaglet baseboard, PCIe switch is not available and the PCIe lane from Apalis module is directly available on mini PCIe slot.

Refer **Figure 5** for PCIe interface realization in Eagle/Eaglet baseboard base board.

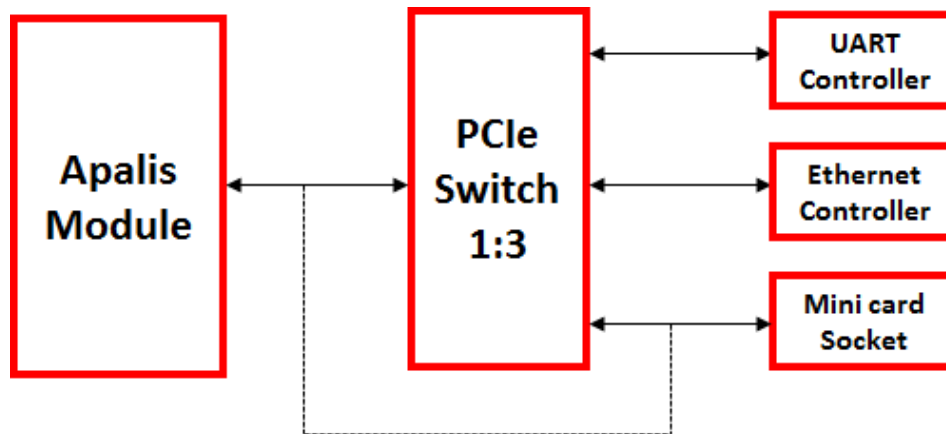

PCIe lane is connected directly to Mini PCIe slot in Low cost Eaglet baseboard

Figure 5 PCIe Interface

3.3.5 mSATA

Eagle and Eaglet baseboard supports the standard mSATA slot (**J28**). SATA signals are directly derived from Apalis module and connected to mSATA connector that allows a miniature SATA disk module to be installed to it and attached with a mounting spacer and screw.

3.3.6 Micro SD (MMC)

Eagle and Eaglet baseboard features 4 bit SD interface. Push-pull micro SD card slot (**J18**) is available on the edge of the baseboard for easy user access.

3.3.7 Display

Eagle and Eaglet baseboard provides 3 display outputs: one VGA, one HDMI and one LVDS. All the display interfaces come directly from the Apalis module.

VGA interface is available on the 2x5 header (**J10**)

HDMI is available on the 2x10 header (**J9**).

Both the VGA and HDMI are available on standard connectors by using a [Panel IO Board](#).

LVDS interface is available on 2x15 shrouded header (**J1**), LVDS backlight power and control signals are available on 1x6 header (**J2**)

Display resolution details:

VGA* : 1280x1024

HDMI: UltraHD (2160p)

LVDS: 1x 1280x1024x24bpp Single or 1x 2048x1536x24bpp Dual

* VGA interface is supported only by iMX6 module.

* Display outputs are Apalis module dependent. Refer [Apalis module specifications](#) for more information.

Related Toradex link:

<http://developer.toradex.com/knowledge-base/display-output-resolution-and-timings-linux>

[http://developer.toradex.com/knowledge-base/framebuffer-\(linux\)](http://developer.toradex.com/knowledge-base/framebuffer-(linux))

3.3.8 Audio

Eagle and Eaglet supports standard Audio interface available on 2x5 Header (**J8**). Audio I/O signals include stereo line in, stereo line out and mic in. Audio signals are available on standard Audio connectors via a [Panel IO Board](#).

Related Toradex link:

[http://developer.toradex.com/knowledge-base/audio-\(linux\)](http://developer.toradex.com/knowledge-base/audio-(linux))

3.3.9 Serial Ports

Eagle baseboard supports up to 8 serial ports. 4 ports come directly from Apalis module and Serial ports 5 to 8 are realized with PCIe to UART chip (XR17V354) All ports supports RS232/422/485 protocol based on the ARM module and the Eagle variant selected. Protocol selection is controlled using GPIOs from I2C to GPIO expander. (Refer [GPIO Handling](#) section for more information.)

Low cost Eaglet features only 4 serial ports, directly coming from Apalis module. Serial ports 1 and 2 are having RS232/422/485 (SP336) capability and serial ports 3 and 4 are fixed with RS232 capability. Jumpers (**JP2**) are used to enable termination resistor (121 Ohm) for RS422 and RS485 protocols.

Serial port 1 acts as a console port by default. Serial ports 1 and 2 are available on 2x5 header (**J11**) and also on standard DB9 connector via a Panel IO board. Serial ports 3 to 8 are available on the 2x5 headers (**J16**, **J21** and **J22**).

Related Toradex link:

[http://developer.toradex.com/knowledge-base/uart-\(linux\)](http://developer.toradex.com/knowledge-base/uart-(linux))

3.3.10 GPIO

Eagle supports up to 16 GPIOs which are 3.3V compatible and 8 Opto-isolated GPIOs. The 8x 3.3 compatible GPIOs are coming directly from Apalis module and are available on 2x5 header (**J6**) and are also available on DB9 male connector via a Panel IO Board. 16x GPIOs are realized from I2C GPIO expander, of which 8 GPIOs are 3.3V compatible and are available on 2x5 header (**J25**). Other 8 GPIOs are configured as opto isolated with 4 input and 4 output configuration and are available on 2x10 header (**J24**)

Low cost Eaglet supports only 8 GPIOs with 3.3V compatibility, directly coming from Apalis.

Relate Toradex Link:

[http://developer.toradex.com/knowledge-base/gpio-\(linux\)](http://developer.toradex.com/knowledge-base/gpio-(linux))

3.3.11 Analog Input

Eagle and Eaglet baseboard provides 4 Analog input channels on 2x5 header (**J3**). Analog inputs have 12-bit resolution and input voltage span from 0 to 3.3V.

Related Toradex Link:

[http://developer.toradex.com/knowledge-base/adc-\(linux\)](http://developer.toradex.com/knowledge-base/adc-(linux))

3.3.12 CAN

Eagle and Eaglet supports 2x CAN ports realized by mounting a [CAN Add-on module](#) on 2x10 header (**J14**).

Related Toradex Link:

[http://developer.toradex.com/knowledge-base/can-\(linux\)](http://developer.toradex.com/knowledge-base/can-(linux))

3.3.13 Serial Camera

Eagle supports 2x Dual lane MIPI CSI2 interface available on 2x10 header (**J26**). Currently the MIPI Add-on module is not supported.

3.3.14 Type Specific Mezzanine

Eagle provides access to the type specific pins on Apalis modules through a dedicated high speed connector.

3.3.15 LED Indicators

The Eagle board provides the following LED indicators. All LEDs are located near to a board edge or their respective features. All LEDs are labeled in silkscreen with their function.

Power on: Green LED when board is powered on

PCIe MiniCard socket: 3 Green LEDs to support WWAN, WPAN, WLAN signals from the connector

SATA Activity: Green LED for SATA activity.
 Apalis Ethernet: Green LEDs for Link and Activity
 Ethernet 10/100/1000: Green LEDs for Link and Activity (Not available on Eaglet)
 PCIe to UART Power: Green LED for PCIe to UART chip Power OK (Not available on Eaglet)

3.3.16 Real-Time Clock (RTC)

The board contains an on-board RTC backup battery (BR-2330A/HDN). Connector (**J5**) is provided to enable the use of an external battery.
 A jumper (**JP1**) is provided to disconnect the battery during long term storage.

3.3.17 Power Supply

Low cost Eaglet board is powered from +5VDC +/- 5% and Eagle baseboard is powered from a wide input voltage range of +9V to +36V.

Input power is provided to Eaglet and Eagle baseboard through pin header [J28](#). All required supply voltages for the board, other than the +12V (for LCD back light), are derived from the input supply.

The on-board power supplies are able to support the below add-on features:

Eaglet:

5V	3.3V	Feature
	1.5A	PCIe mini card
	1.5A	mSATA
1.4A	0.7A	LVDS LCD
0.5A	0.5A	CAN Header
	0.1A	GPIO Header

Eagle:

5V	3.3V	Feature
	1.5A	PCIe mini card
	1.5A	mSATA
1.4A	0.7A	LVDS LCD
0.5A	0.5A	CAN Header
	0.3A	GPIO Headers (3)
	0.1A	CSI
	0.2A	Type Specific

4 Mechanical BOARD DRAWING

4.1 Eaglet Baseboard

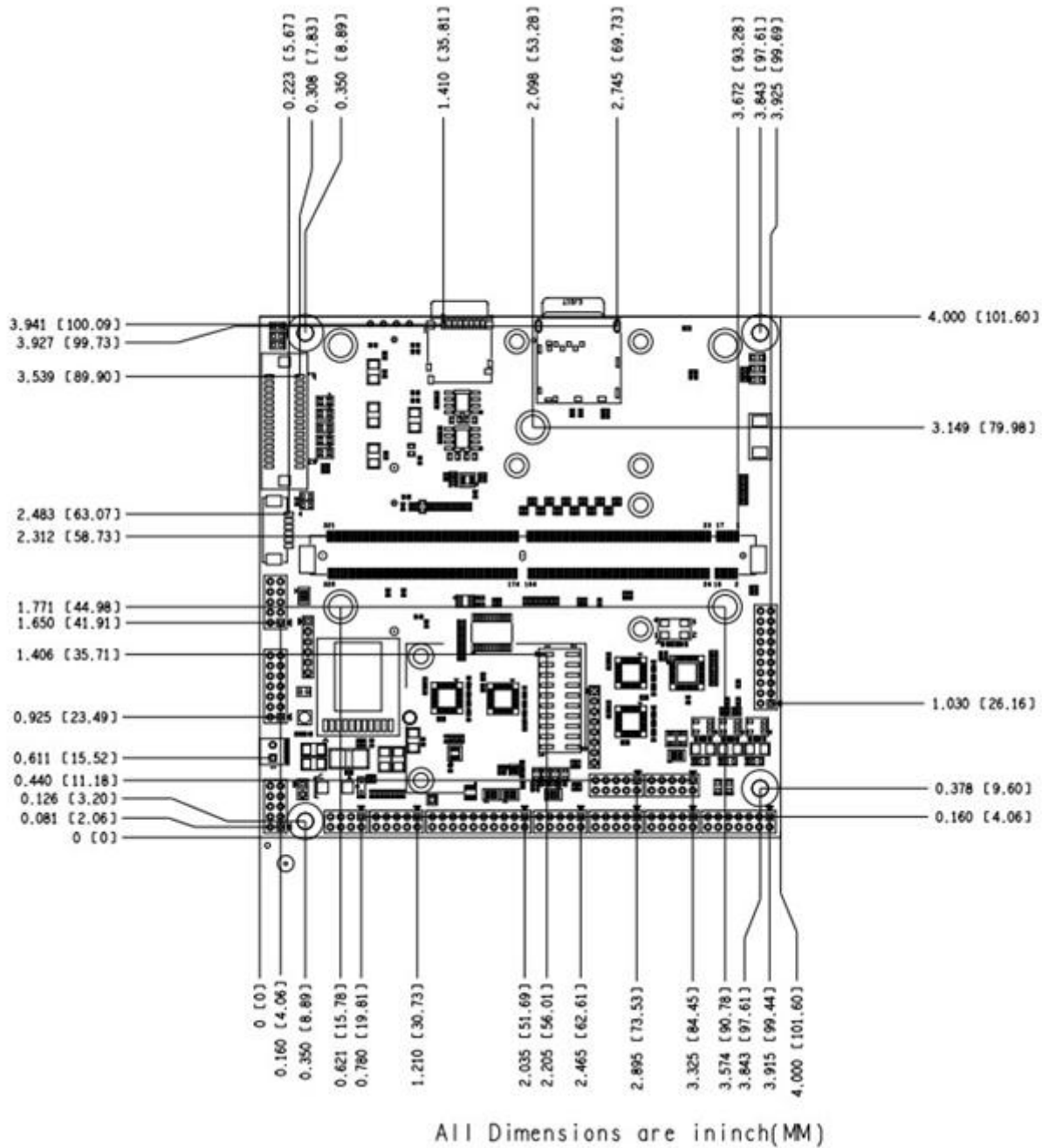

Figure 6 Eaglet Baseboard Mechanical drawing

4.2 Eagle Baseboard

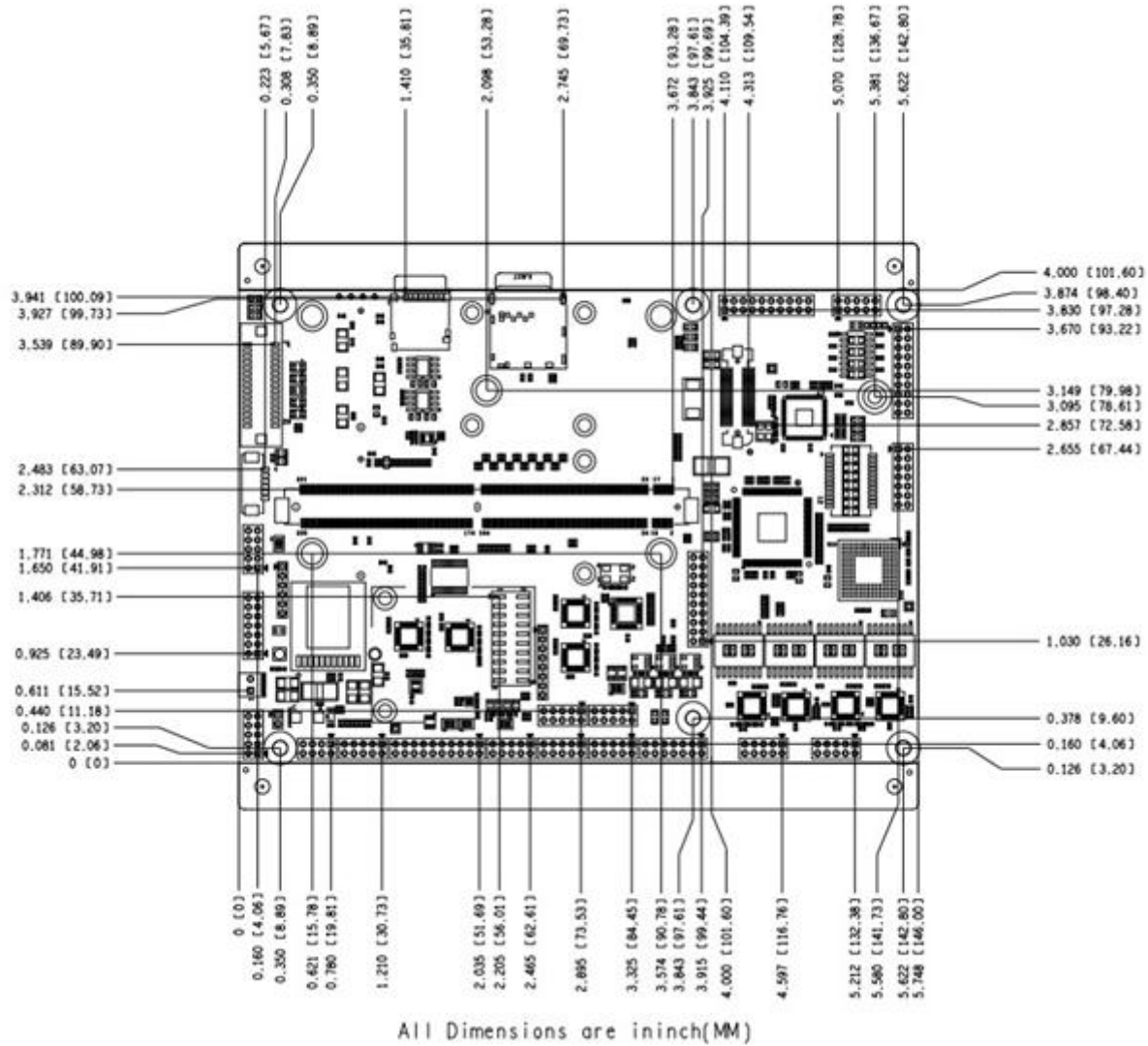

Figure 7 Eagle Baseboard Mechanical drawing

5 Board Layout (Connector and Jumper Locations)

5.1 Eagle Baseboard

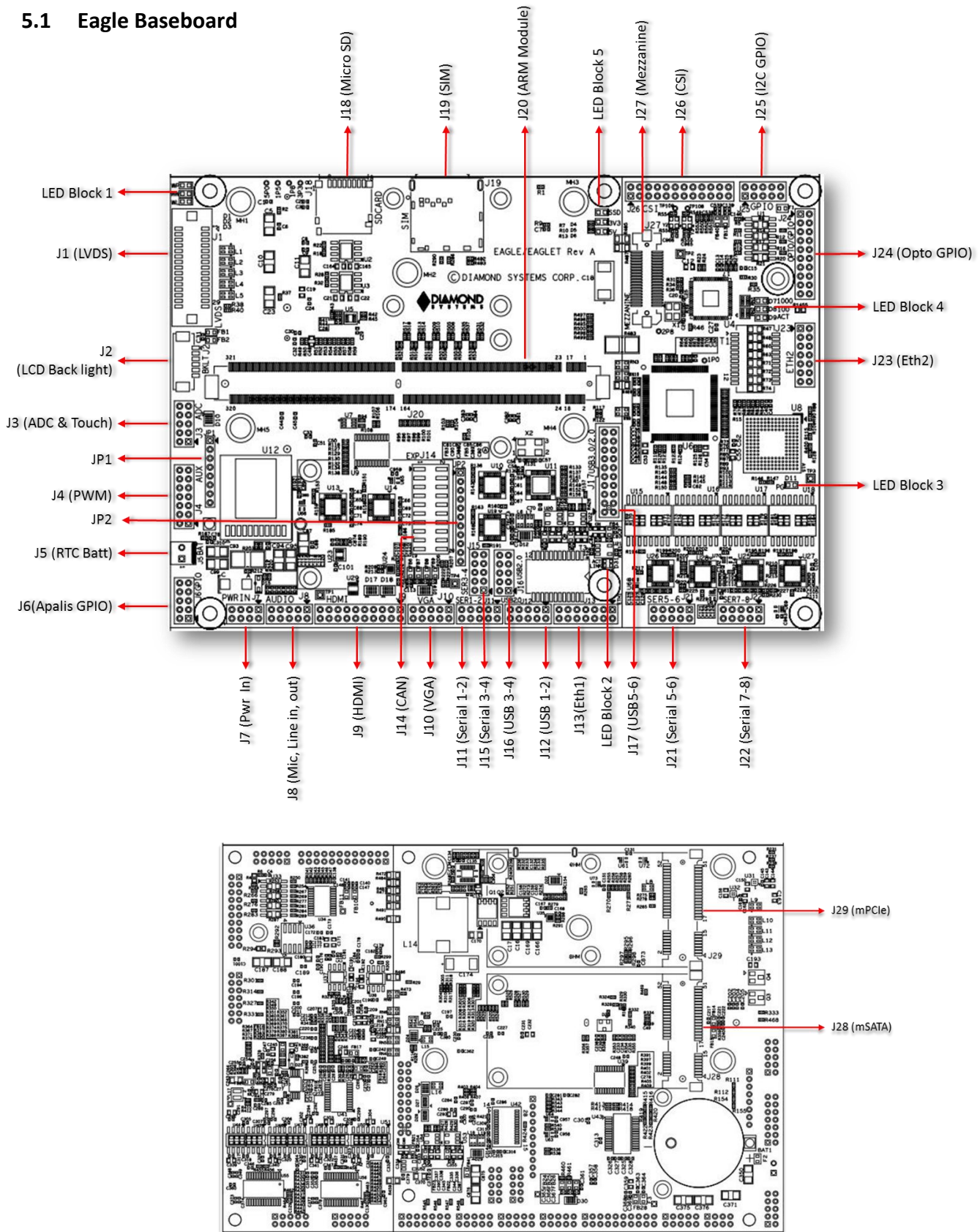

Figure 8 Board Layout, Top view and bottom view

I/O Connectors, Jumpers and LED Summary for Eagle

Connector	Function	Jumper	Function
J1	LVDS LCD	JP1	LVDS Supply, Back light and NVRAM supply selection
J2	LCD Backlight	JP2	USB Port 5 Mode and RS422/485 termination
J3	Touch/Analog Inputs	LED Block 1	
J4	Auxiliary/PWM	1 st LED (Topmost in block)	WPAN (WP)
J5	External Battery - RTC	2 nd LED (Second from top in block)	WWAN (WW)
J6	Apalis GPIOs	3 rd LED (Third from top in block)	WLAN (WL)
J7	Power supply and LCD backlight supply Input	LED Block 2	
J8	Audio	1 st LED (Topmost in block)	Eth-1 Activity (Red color)
J9	HDMI	2 nd LED (Second one in block)	Eth-1 Link (Green color)
J10	VGA	LED Block 3	
J11	Apalis UARTs – Port 1 & 2	1 st LED (D11)	EXAR PGOOD
J12	USB 2.0 Ports 1 & 2	LED Block 4	
J13	Apalis Ethernet (Eth-1)	1 st LED (Topmost in the block)	Eth-2 1000BASE-T Link
J14	CAN Add on card connector	1 st LED (Second one in the block)	Eth-2 100BASE-T Link
J15	Apalis UARTs – Port 3 & 4	1 st LED (Bottom one in the block)	Eth-2 Activity
J16	USB 2.0 Ports 3 & 4	LED Block 5	
J17	USB 3.0 Ports – 5 & 6	1 st LED (Topmost in the block)	SATA Activity
J18	SD Card	1 st LED (Second one in the block)	3.3V Supply
J19	SIM	1 st LED (Bottom one in the block)	5V Supply
J20	ARM Module		
J21	EXAR UARTs Port 5 & 6		
J22	EXAR UARTs Port 7 & 8		
J23	PCIe Ethernet (Eth-2)		

J24	I2C Opto GPIOs
J25	I2C GPIOs
J26	CSI
J27	Mezzanine Connector
J28	mSATA
J29	Mini Card

5.2 Eaglet Baseboard

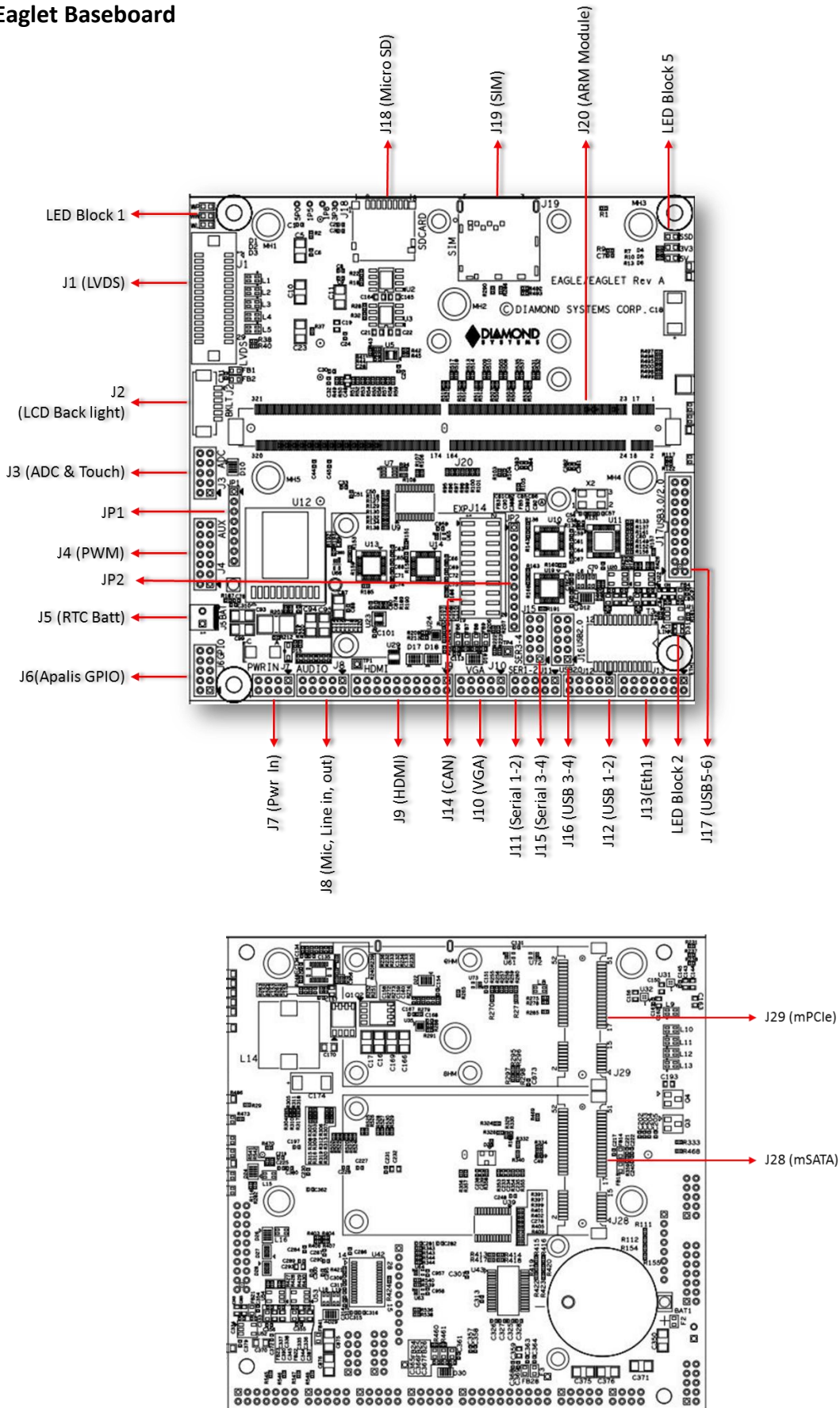

Figure 9 Eaglet board layout, Top and bottom view

5.2.1 I/O Connectors, Jumpers and LED Summary for Eaglet

Connector	Function	Jumper	Function
J1	LVDS LCD	JP1	LVDS Supply, Back light and NVRAM supply selection
J2	LCD Backlight	JP2	USB Port 5 Mode and RS422/485 termination
J3	Touch/Analog Inputs	LED Block 1	
J4	Auxiliary/PWM	1 st LED (Topmost in block)	WPAN (WP)
J5	External Battery - RTC	2 nd LED (Second from top in block)	WWAN (WW)
J6	Apalis GPIOs	3 rd LED (Third from top in block)	WLAN (WL)
J7	Power supply and LCD backlight supply Input	LED Block 2	
J8	Audio	1 st LED (Topmost in block)	Eth-1 Activity (Red color)
J9	HDMI	2 nd LED (Second one in block)	Eth-1 Link (Green color)
J10	VGA	LED Block 5	
J11	Apalis UARTs – Port 1 & 2	1 st LED (Topmost in the block)	SATA Activity
J12	USB 2.0 Ports 1 & 2	1 st LED (Second one in the block)	3.3V Supply
J13	Apalis Ethernet (Eth-1)	1 st LED (Bottom one in the block)	V Supply
J14	CAN Add on card connector		
J15	Apalis UARTs – Port 3 & 4		
J16	USB 2.0 Ports 3 & 4		
J17	USB 3.0 Ports – 5 & 6		
J18	SD Card		
J20	ARM Module		
J23	PCIe Ethernet (Eth-2)		
J28	mSATA		
J29	Mini Card		

6 IO Connectors

6.1 Connector Pin-out and Signal Description

6.1.1 Eaglet and Eagle Baseboard

Following section describes the IO connector details available in both Eaglet and Eagle Baseboard.

6.1.1.1 SD/MMC (J18)

4 bit SD lines are connected to standard micro SD card with following pinout

1	MMC1_D2
2	MMC1_D3
3	MMC1_CMD
4	V_3P3/1P8
5	MMC1_CLK
6	GND_A_REG
7	MMC1_D0
8	MMC1_D1
9	GND_SD_SHEILD
10	GND_SD_SHEILD
11	GND_A_REG
12	MMC1_CD#
13	GND_SD_SHEILD
14	GND_SD_SHEILD

Connector Type: Standard micro SD card slot

6.1.1.2 LVDS (J1)

J1 is a LVDS connector. Pinout is as given below.

VDD 5V	1	2	VDD 5V
VDD 3.3V	3	4	VDD 3.3V
CLK+ Odd	5	6	CLK+ Even
CLK- Odd	7	8	CLK-Even
GND	9	10	GND
D0+ Odd	11	12	D0+ Even
D0- Odd	13	14	D0- Even
D1+ Odd	15	16	D1+ Even
D1- Odd	17	18	D1- Even
D2+ Odd	19	20	D2+ Even
D2- Odd	21	22	D2- Even
D3+ Odd	23	24	D3+ Even
D3- Odd	25	26	D3- Even
GND	27	28	GND
DDC CLK	29	30	DDC DATA

Connector Type: Thirty pin connector from Hirose, DF13A-30DP-1.25V

6.1.1.3 Gigabit Ethernet (J13)

Gigabit Ethernet from Apalis module are directly connected to J13. Pinout is as below.

NC	1	2	GND
DA+	3	4	DA-
DB+	5	6	DB-
DC+	7	8	DC-
DD+	9	10	DD
ACT	11	12	LINK_1000
LINK_100	13	14	V_3P3

Connector Type: Standard 2mm dual row straight pin header.

6.1.1.4 LCD Backlight Connector (J2)

Connector J2 is used for the LCD backlight control. Input power source is user selectable using jumpers (**JP1**) to 5V or 12V.

Brightness may be controlled over PWM (pin 6) on this connector. Option is available to set the PWM voltage level to 3.3V or 5V using jumper (JP1).

1	Power +5V/+12V, jumper selectable
----------	-----------------------------------

2	Power (same as pin 1)
3	Ground
4	Ground
5	Enable (GPIO output), 0 = off, open circuit = on
6	PWM, 5V/ 3.3V level jumper selectable

Connector Type: 6 pin RA 1.25mm pitch SMD header (053261-0671 from Molex).

Mating Housing: 51021-0600

Crimp terminal: 50058-8000

6.1.1.5 Analog IO/ Resistive Touch (J3)

Analog IOs and Resistive touch signals are terminated at J3 with below pinouts.

AN1_ADC0	1	2	AN1_ADC3
AN1_ADC1	3	4	AN1_ADC2
AGND	5	6	AGND
AN1_TSMX	7	8	AN1_TSPX
AN1_TSMY	9	10	AN1_TSPY

Connector Type: Standard 2mm dual row straight pin header.

6.1.1.6 USB3.0 Ports (J17)

1x USB3.0 and 1xOTG signals are available at J17. Standard pinout from Intel is followed.

VCC_USBH4	1	2	KEY
USBH4_SSRX_N	3	4	VCC_USBO1
USBH4_SSRX_P	5	6	USBO1_SSRX_N
GND	7	8	USBO1_SSRX_P
USBH4_SSTX_N	9	10	GND
USBH4_SSTX_P	11	12	USBO1_SSTX_N
GND_A_REG	13	14	USBO1_SSTX_P
USBH4_D_CON_N	15	16	GND
USBH4_D_CON_P	17	18	USBO1_D_CON_N
USBO1_ID	19	20	USBO1_D_CON_P

Connector Type: Standard 2mm dual row straight pin header for USB3.0.

6.1.1.7 I2C/PWM/SPI/SPDIF Header (J4)

I2C, SPI, PWM and S/PDIF signals from Apalis module are connected to J4. Below are the pinout details.

PWM1	1	2	V_3P3
------	----------	----------	-------

PWM2	3	4	I2C3_CAM_SCL
PWM3	5	6	I2C3_CAM_SDA
SPDIF_IN	7	8	SPI2_SCLK
SPDIF_OUT	9	10	SPI2_CSN
AUX_GPIO0_7	11	12	SPI2_MISO
GND	13	14	SPI2_MOSI

Connector Type: Standard 2mm dual row straight pin header.

6.1.1.8 CAN Header (J14)

2x CAN ports from Apalis module are terminated to J14. CAN Mezzanine module to be fixed to J14 to avail the CAN ports. Below are the pinout details

VCC_5V	1	2	V_3P3
CAN1_TX	3	4	CAN1_RX
CAN2_TX	5	6	CAN2_RX
I2C1_SCL	7	8	SPI1_CLK
I2C1_SDA	9	10	SPI1_CSN
CAN_GPIO1	11	12	SPI1_MISO
CAN_GPIO2	13	14	SPI1_MOSI
CAN_GPIO3	15	16	NC
NC	17	18	NC
GND	19	20	GND

Connector Type: Standard 2mm dual row straight pin header.

6.1.1.9 External Battery (J5)

Connector J5 may be used to enable the use of an external battery.

1	VBAT
2	Ground

VBAT = +3.3V

Connector Type: Hirose DF13A-2P-1.25H right-angle friction lock pin header.

6.1.1.10 Serial Ports 1-4 (J11, J15)

There are two serial port connectors J11 and J15, supporting two ports per connector. Serial ports 1 and 2 (J11) are available on [Panel IO](#) board with standard DB9 connector

For Eaglet variant, Serial ports 1-2 supports RS232, RS485 and RS422 mode (SP336). For RS422/RS485 mode 120E termination to be enabled by placing the jumpers on [JP2](#). Serial port 3-4 supports only RS232 mode in low cost Eaglet model.

For Full feature Eagle model, Serial Ports 1-4 supports RS232, RS485 and RS422 modes (SP335). Pinout for SP336 and SP335 featured board differs for RS422/RS485 mode.

RS232

TX1	1	2	RTS1
RX1	3	4	CTS1
GND	5	6	GND
TX2	7	8	RTS2
RX2	9	10	CTS2

RS422/SP336 (Eaglet)

TX1+	1	2	TX1-
RX1+	3	4	RX1-
GND	5	6	GND
TX2+	7	8	TX2-
RX2+	9	10	RX2-

RS422/SP335 (Eagle)

TX1-	1	2	TX1+
RX1+	3	4	RX1-
GND	5	6	GND
TX2-	7	8	TX2+
RX2+	9	10	RX2-

RS485/SP336 (Eaglet)

TX1/RX1+	1	2	TX1/RX1-
NC	3	4	NC
GND	5	6	GND
TX2/RX2+	7	8	TX2/RX2-
NC	9	10	NC

RS485/SP335 (Eagle)

TX1/RX1-	1	2	TX1/RX1+
NC	3	4	NC
GND	5	6	GND
TX2/RX2-	7	8	TX2/RX2+
NC	9	10	NC

Connector Type: Standard 2mm dual row straight pin header.

Following table provides details about serial ports available on different connector.

Connector	Serial Ports	Comments
J11	Port 1	Pins 1 to 4
	Port 2	Pins 7 to 10
J15	Port 3	Pins 1 to 4
	Port 4	Pins 7 to 10

6.1.1.11 USB2.0 Ports (J12, J16)

There are two USB2.0 connectors with identical pinouts, J12 and J16. Each connector provides access to two USB 2.0 ports summing up to four USB2.0 ports. Connector J16 is available only in Full feature Eagle baseboard.

Key	1	2	Shield
USB1 Pwr-	3	4	USB0 Pwr-
USB1 Data+	5	6	USB0 Data+
USB1 Data-	7	8	USB0 Data-
USB1 Pwr+	9	10	USB0 Pwr+

Connector Type: Standard 2mm dual row straight pin header.

6.1.1.12 GPIOs (J6)

GPIOs from Apalis are available on J6. Numbers inside brackets are the alphanumeric mappings for the corresponding GPIOs based on the ARM module used.

GPIO1 (iMx-36, T30-146)	1	2	GPIO2(iMx-37, T30-147)
GPIO3(iMx-38, T30-148)	3	4	GPIO4 (iMx-39, T30-149)
GPIO5(iMx-170, T30-150)	5	6	GPIO6 (iMx-169, T30-128)
GPIO7(iMx-2, T30-151)	7	8	GPIO8 (iMx-6, T30-129)
RESET_MICO _n	9	10	GND

Connector Type: Standard 2mm dual row straight pin header.

6.1.1.13 HDMI (J9)

HDMI signals are connected to J9. Pinout is as below.

HDMI_TXD2_P	1	2	GND
HDMI_TXD2_N	3	4	HDMI_TXD1_P
GND	5	6	HDMI_TXD1_N
HDMI_TXD0_P	7	8	GND
HDMI_TXD0_N	9	10	HDMI_TXC_P
GND	11	12	HDMI_TXC_N
HDMI_CEC	13	14	NC
HDMI_DDC_CLK	15	16	HDMI_DDC_DATA
GND	17	18	5V
HDMI_HPD	19	20	NC

Connector Type: Standard 2mm dual row straight pin header.

6.1.1.14 Audio (J8)

Audio signals are terminated onto connector J8 with following pinout.

LineOut-L	1	2	LineOut-R
GND_Audio	3	4	GND_Audio
LineIn-L	5	6	LineIn-R
GND_Audio	7	8	GND_Audio
NC	9	10	MIC_R

Connector Type: Standard 2mm dual row straight pin header

6.1.1.15 VGA (J10)

A VGA monitor can be plugged into connector J10.

RED	1	2	Ground
GREEN	3	4	Key
BLUE	5	6	Ground
HSYNC	7	8	DDC-Data
VSYNC	9	10	DDC-Clock

Connector Type: Standard 2mm dual row straight pin header.

6.1.1.16 Power in (J7)

Input power maybe supplied through J7.

GND	1	2	+VIN/V_5P0
GND	3	4	+VIN/V_5P0
GND	5	6	+VIN/V_5P0
V_12P0	7	8	+VIN/V_5P0

Connector Type: Standard 2mm dual row straight pin header.

6.1.1.17 Mini PCIe Card (J29)

All TX/RX signals are with respect to the host. TX on the socket drives RX on the installed module, and RX on the socket is driven by TX on the installed module.

Provided an option to mount both half sized and full sized mini card.

Wake#	1	2	+3.3V
NC	3	4	Gnd
NC	5	6	+1.5V
NC	7	8	SIM_VDD
Gnd	9	10	SIM_DATA
PCIe Ref Clk-	11	12	SIM_CLK
PCIe Ref Clk+	13	14	SIM_RST
Gnd	15	16	SIM_VPP
KEY			
NC	17	18	Gnd
NC	19	20	WLAN_Disable#
Gnd	21	22	PCIe Reset#
PCIe RX-	23	24	+3.3V
PCIe RX+	25	26	Gnd
Gnd	27	28	+1.5V
Gnd	29	30	SMB Clk
PCIe TX-	31	32	SMB Data
PCIe TX+	33	34	Gnd
Gnd	35	36	USB DATA-
Gnd	37	38	USB DATA+
+3.3V	39	40	Gnd
+3.3V	41	42	WWAN LED#
Ground	43	44	WLAN LED#
NC	45	46	WPAN LED#

NC	47	48	+1.5V
Pull-up to +3.3V	49	50	Gnd
NC	51	52	+3.3V

Connector Type: 52-pin MiniCard, full size/half size, with PCB mount threaded spacers

6.1.1.18 mSATA (J28)

All TX/RX signals are with respect to the host. TX on the socket drives RX on the installed module, and RX on the socket is driven by TX on the installed module.

NC	1	2	+3.3V
NC	3	4	Gnd
NC	5	6	+1.5V
NC	7	8	NC
Gnd	9	10	NC
NC	11	12	NC
NC	13	14	NC
Gnd	15	16	NC
KEY			
NC	17	18	Gnd
NC	19	20	NC
Gnd	21	22	NC
SATA 0 RX+	23	24	+3.3V
SATA 0 RX-	25	26	Gnd
Gnd	27	28	+1.5V
Gnd	29	30	SMB Clk
SATA 0 TX-	31	32	SMB Data
SATA 0 TX+	33	34	Gnd
Gnd	35	36	NC
Gnd	37	38	NC
+3.3V	39	40	Gnd
+3.3V	41	42	NC
NC	43	44	NC
NC	45	46	NC
NC	47	48	+1.5V
NC	49	50	Gnd
NC	51	52	+3.3V

Connector Type: 52-pin MiniCard, full size, with PCB mount threaded spacers

6.1.2 Eagle Baseboard

In addition to the list of connectors mentioned in the section 6.1.1, Eagle has the following additional connectors.

(These connectors are available only in Eagle)

6.1.2.1 GPIO Header (J25)

GPIO Signals from I2C GPIO expander are connected to J25 with following pinout. Numbers inside brackets are the alphanumeric mappings for the corresponding GPIOs to be used in the GPIO utility.

EXP_GPIO1_0 (456)	1	2	EXP_GPIO1_1 (457)
EXP_GPIO1_2 (458)	3	4	EXP_GPIO1_3 (459)
EXP_GPIO1_4 (460)	5	6	EXP_GPIO1_5 (461)
EXP_GPIO1_6 (462)	7	8	EXP_GPIO1_7 (463)
V_3P3	9	10	GND

Connector Type: Standard 2mm dual row straight pin header.

6.1.2.2 CSI (J26)

Dual lane CSI2 MIPI signals are available on J26 with following pinout. MIPI Add-on module can be fixed to J26 to connect standard MIPI camera.

CSI1_CLKA_N	1	2	CSI2_CLKB_N
CSI1_CLKA_P	3	4	CSI2_CLKB_P
GND_DIG	5	6	GND_DIG
CSI1_D1A_N	7	8	CSI1_D1B_N
CSI1_D1A_P	9	10	CSI1_D1B_P
GND_DIG	11	12	GND_DIG
CLK_24M_MIPI1	13	14	CLK_24M_MIPI2
I2C_CSI_SDA	15	16	I2C_CSI_SCL
Pull Down to GND_DIG	17	18	Pull Down to GND_DIG
Pull Down to GND_DIG	19	20	Pull Down to GND_DIG
VCA3P3	21	22	VCA2V8
VCA1P8	23	24	VCA1P5

Connector Type: Standard 2mm dual row straight pin header.

6.1.2.3 Micro SIM Card Slot (J19)

SIM interface from mini PCIe card is connected to micro SIM card slot J19 with following pinout. SIM card slot is available on request basis.

C1	SIM_VDD
C2	R_SIM_RST
C3	R_SIM_CLK
C5	GND_A_REG
C6	SIM_VPP
C7	R_SIM_DATA
SW	SIM_CD

Connector Type: Standard micro SIM card slot

6.1.2.4 Opto GPIO (J24)

8 Opto isolated GPIOs are connected to J24 with following pinout. Numbers inside brackets are the alphanumeric mappings for the corresponding GPIOs to be used in the GPIO utility.

V_OPTO	1	2	NC
OPTO_EXP_DIN1+ (448)	3	4	OPTO_EXP_DIN2+ (449)
OPTO_EXP_DIN3+ (450)	5	6	OPTO_EXP_DIN4+ (451)
OPTO_EXP_DOUT1+ (452)	7	8	OPTO_EXP_DOUT2+ (453)
OPTO_EXP_DOUT3+ (454)	9	10	OPTO_EXP_DOUT4+ (455)
OPTO_EXP_DIN1-	11	12	OPTO_EXP_DIN2-
OPTO_EXP_DIN3-	13	14	OPTO_EXP_DIN4-
OPTO_EXP_DOUT1-	15	16	OPTO_EXP_DOUT2-
OPTO_EXP_DOUT3-	17	18	OPTO_EXP_DOUT4-
V_3P3	19	20	GND

Non Opto Version (J24)

NC	1	2	NC
NC	3	4	NC
NC	5	6	NC
NC	7	8	NC
NC	9	10	NC
I2C_EXP_DIN1 (448)	11	12	I2C_EXP_DIN2 (449)
I2C_EXP_DIN3 (450)	13	14	I2C_EXP_DIN4 (451)
I2C_EXP_DOUT1 (452)	15	16	I2C_EXP_DOUT2 (453)
I2C_EXP_DOUT3 (454)	17	18	I2C_EXP_DOUT4 (455)
V_3P3	19	20	GND

Connector Type: Standard 2mm dual row straight pin header.

6.1.2.5 Type Specific (J27)

Type specific IOs from Apalis module are available at J27. Pinouts are as below.

V_3P3	1	2	V_1P8
TS_4	3	4	TS_1
TS_5	5	6	TS_2
TS_6	7	8	TS_3
GND	9	10	GND
TS_DIFF1_N	11	12	TS_DIFF2_N
TS_DIFF1_P	13	14	TS_DIFF2_P
TS_DIFF3_N	15	16	TS_DIFF4_N
TS_DIFF3_P	17	18	TS_DIFF4_P
GND	19	20	GND
TS_DIFF5_N	21	22	TS_DIFF6_N
TS_DIFF5_P	23	24	TS_DIFF6_P
TS_DIFF7_N	25	26	TS_DIFF8_N
TS_DIFF7_P	27	28	TS_DIFF8_P
GND	29	30	GND
TS_DIFF9_N	31	32	TS_DIFF10_N
TS_DIFF9_P	33	34	TS_DIFF10_P
TS_DIFF11_N	35	36	TS_DIFF12_N
TS_DIFF11_P	37	38	TS_DIFF12_P
GND	39	40	GND

Connector Type: Dual row 40 position receptacle from Molex, 0528850474

6.1.2.6 Ethernet (PCIe) (J23)

Gigabit Ethernet from PCIe to Ethernet are connected to J23 with necessary magnetics. Pinout is as below.

NC	1	2	GND
DA+	3	4	DA-
DB+	5	6	DB-
DC+	7	8	DC-
DD+	9	10	DD
ACT	11	12	NC
LINK	13	14	V_3P3

Connector Type: Standard 2mm dual row straight pin header.

6.1.2.7 Serial Ports 5-8 (J21, J22)

There are two serial port connectors J21 and J22, supporting two ports per connector. All the serial ports support RS232, RS485 and RS422 modes. For simplicity only the pinout for ports 5 and 6 are shown; ports 7 and 8 are similar.

RS-422

TX5	1	2	RTS5
RX5	3	4	CTS5
GND	5	6	GND
TX6	7	8	RTS6
RX6	9	50	CTS6

RS-422

TX5-	1	2	TX5+
RX5+	3	4	RX5+
GND	5	6	GND
TX6-	7	8	TX6+
RX6+	9	50	RX6-

RS-485

TX5/RX5-	1	2	TX5/RX5+
NC	3	4	NC
GND	5	6	GND
TX6/RX6-	7	8	TX6/RX6+
NC	9	10	NC

The following table provides details about the serial ports available on the two connectors.

Connector	Serial Ports	Connector Pins
J21	Port 5	Pins 1 to 4
	Port 6	Pins 7 to 10
J22	Port 7	Pins 1 to 4
	Port 8	Pins 7 to 10

6.2 List of Connectors

6.2.1 Eaglet Baseboard

The following table provides a summary of all I/O connectors on the Eaglet baseboard and their associated DSC cable part number.

Function	Reference	Manufacturer	Part no.	Description	Mating Cable
Analog IO	J3	Pinrex	220-9205GB01	2x5, 2mm pitch, TH header	6981169
Serial Ports Qty=2	J11,J15,J216,J22	Pinrex	220-9205GB01	2x5, 2mm pitch, TH header	6981075
GPIO	J25	Pinrex	220-9205GB01	2x5, 2mm pitch, TH header	6981169
Audio	J8	Pinrex	220-9205GB01	2x5, 2mm pitch, TH header	6981076
VGA	J10	Pinrex	220-9205GB01	2x5, 2mm pitch, TH header	6981084
USB2.0	J12,J16	Pinrex	220-9205GB01	2x5, 2mm pitch, TH header	6091082
HDMI	J9	Pinrex	220-9210GB01	2x10, 2mm pitch, TH header	6980522
I2C/PWM	J4	Pinrex	220-9207GB01	2x7, 2mm pitch, TH header	6980523
10/100/1000 Ethernet	J23,J13	Pinrex	220-9207GB01	2x7, 2mm pitch, TH header	6980521
Power In	J7	Pinrex	220-9204GB01	2x4, 2mm pitch, TH header	6980520
External Battery	J5	TE	640456-2	2 pos. 1.27mm pitch, SMT	6981011
CAN	J14	Pinrex	222-9210GB01	Conn 2mm housing SMD 20pos dual	NA
LVDS	J1	Hirose Electric	DF13A-30DP-1.25V	2x 15, 1.25MM SMT, Vertical	6981215
USB3.0/OTG	J17	Win Win precision	WUIR-19A1N4BU3N	2x10, 2mm pitch, TH header	6980100
mini PCIe	J29	JAE	MM60-52B1-E1-R650	52-pin MiniCard, full size, with PCB mount threaded spacers	NA
mSATA	J28	JAE	MM60-52B1-E1-R650	52-pin MiniCard, full size, with PCB mount threaded spacers	NA
LCD Backlight	J2	Molex	053261-0671	6 pos. 1.25mm pitch, SMT, RA	6981216
Micro SD	J18	Amphenol Corporation	114-00841-68	Conn micro SD card push-push RA	NA

6.2.2 Eagle Baseboard

The following table provides a summary of all I/O connectors on the Eagle baseboard.

Function	Reference	Manufacturer	Part no.	Description	Mating Cable
Analog IO	J3	Pinrex	220-9205GB01	2x5, 2mm pitch, TH header	6981169
Serial Ports Qty=4	J11,J15,J216,J22	Pinrex	220-9205GB01	2x5, 2mm pitch, TH header	6981075
GPIO	J25	Pinrex	220-9205GB01	2x5, 2mm pitch, TH header	6981169
Audio	J8	Pinrex	220-9205GB01	2x5, 2mm pitch, TH header	6981076
VGA	J10	Pinrex	220-9205GB01	2x5, 2mm pitch, TH header	6981084
USB2.0	J12,J16	Pinrex	220-9205GB01	2x5, 2mm pitch, TH header	6091082
HDMI	J9	Pinrex	220-9210GB01	2x10, 2mm pitch, TH header	6980522
I2C/PWM	J4	Pinrex	220-9207GB01	2x7, 2mm pitch, TH header	6980523
10/100/1000 Ethernet Qty=2	J23,J13	Pinrex	220-9207GB01	2x7, 2mm pitch, TH header	6980521
Power In	J7	Pinrex	220-9204GB01	2x4, 2mm pitch, TH header	6980520
External Battery	J5	TE	640456-2	2 pos. 1.27mm pitch, SMT	6981011
CAN	J14	Pinrex	222-9210GB01	Conn 2mm housing SMD 20pos dual	NA
LVDS	J1	Hirose Electric Co Ltd	DF13A-30DP-1.25V	2x 15, 1.25MM SMT, Vertical	6981215
USB3.0/OTG	J17	Win Win precision	WUIR-19A1N4BU3N	2x10, 2mm pitch, TH header	6980100
mini PCIe	J29	JAE	MM60-52B1-E1-R650	52-pin MiniCard, full size, with PCB mount threaded spacers	NA
mSATA	J28	JAE	MM60-52B1-E1-R650	52-pin MiniCard, full size, with PCB mount threaded spacers	NA
LCD Backlight	J2	Molex	053261-0671	6 pos. 1.25mm pitch, SMT, RA	6981216
Micro SD	J18	Amphenol Corporation	114-00841-68	Conn micro SD card push-push RA	NA
I2C Expander GPIO	J25	Pinrex	220-9205GB01	2x5, 2mm pitch, TH header	6981169
CSI	J26	Pinrex	220-9210GB01	2x10, 2mm pitch, TH header	NA
Opto GPIO	J24	Pinrex	220-9210GB01	2x10, 2mm pitch, TH header	6981164
Mezzanine	J27	Molex	528850474	2x20, 0.67mm, SMT	NA
micro SIM	J19	TE Connectivity	2174803-2	Micro SIM card slot	NA

7 I/O Cables

7.1 Eagle Baseboard

The following Table provides I/O cable details for Eaglet baseboard

Function	DSC cable no.	Ref	Remarks
LVDS LCD	6981213	J1	Not part of cable kit
LCD backlight	6981214	J2	Not part of cable kit
A/D, GPIO, resistive touch	6981169	J3	
Misc. I/O: SPI, I2C, SPDIF	6980523	J4	
External battery input	6981011	J5	
GPIO - Module	6981169	J6	
Power in	6980520	J7	
Audio	6981076	J8	
HDMI	6980522	J9	
VGA	6981084	J10	
Serial ports 1, 2	6981075	J11	
USB 2.0 dual (3,4)	6981082	J12	
Gigabit Ethernet from module	6981080	J13	
CAN Header 1	NA	J14	6981182 for DS-MPE-CAN2L Module
CAN Header 2	NA	J14	
Serial ports 3, 4	6981075	J15	
USB 2.0 dual (1,2)	6981082	J16	
USB 3.0 dual	6980100	J17	
Serial ports 5, 6	6981075	J21	
Serial ports 7, 8	6981075	J22	
Gigabit Ethernet from expansion	6981080	J23	
Opto GPIO	6981164	J24	
GPIO - I2C expander	6981169	J25	

7.2 Eaglet Baseboard

Following Table provides I/O cable details for Eaglet baseboard

SL No.	Function	DSC cable no.	Ref	Remarks
1	LVDS LCD	6981213	J1	Not part of cable kit
2	LCD backlight	6981214	J2	Not part of cable kit
3	A/D, GPIO, resistive touch	6981169	J3	
4	Misc. I/O: SPI, I2C, SPDIF	6980523	J4	
5	External battery input	6981011	J5	
6	GPIO - Module	6981169	J6	
7	Power in	6980520	J7	
8	Audio	6981076	J8	
9	HDMI	6980522	J9	
10	VGA	6981084	J10	
11	Serial ports 1, 2	6981075	J11	
12	USB 2.0 dual (3,4)	6981082	J12	
13	Gigabit Ethernet from module	6981080	J13	
14	CAN Header 1	NA	J14	6981182 for CAN Transceiver Module
15	CAN Header 2	NA	J14	
16	Serial ports 3, 4	6981075	J15	
17	USB 2.0 dual (1,2)	6981082	J16	
18	USB 3.0 dual	6980100	J17	

8 Jumper Description

Following drawing shows only the connectors and jumper blocks on both Eagle and Eaglet. The default jumper positions are shown in red.

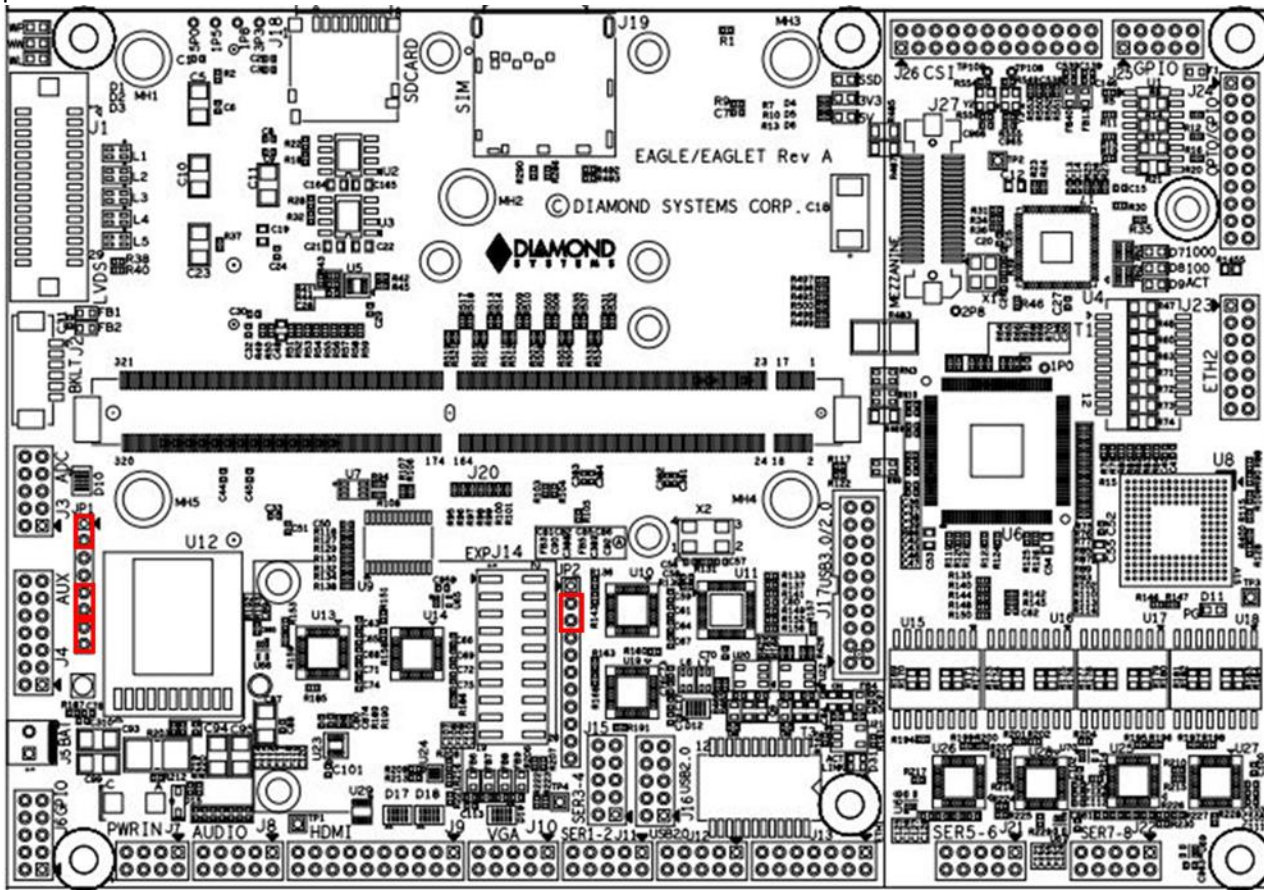

Figure 10 Default Jumper locations

<i>Jumper</i>	<i>Description</i>
JP1	LVDS Supply, Back light and NVRAM supply selection
JP2	USB Port 5 Mode and RS422/485 termination

8.1 LVDS VCC, Backlight & RTC (JP1)

Jumper block JP1 configures the voltage supply for the LVDS backlight and for LVDS VDD as well. The orientation of the block in the diagrams matches the orientation of the jumper block when the board is rotated so that the Apalis module is on the Top edge.

Available options for Back light are +5V and +12V. +12V is not used by any circuit on the Eagle. +12V is needed for the LCD backlight, and the backlight is to be powered via the backlight power connector J10, hence +12V is supplied on the main power input connector along with +VIN.

By default LVDS backlight is provided with +12V and the LVDS VDD is provided with 3.3V. Figure 11 shows the default jumper locations.

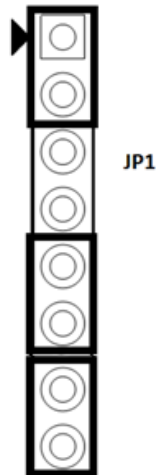

Figure 11 Jumper Block JP1

The following table shows different combinations of jumper locations on JP1.

1-2	2-3	4-5	5-6	LVDS Backlight	LVDS VDD
In	Out	In	Out	12V	5V
In	Out	Out	In	12V	3.3V
Out	In	In	Out	5V	5V
Out	In	Out	In	5V	3.3V

7-8	RTC
In	On board battery
Out	External 3.3V batter

Note:

1. The voltage selected on the backlight connector will not depend on or affect the voltage supply on the LVDS connector.
2. **Do not install a jumper on 3-4 and 6-7 positions.**

8.2 USB OTG & RS422/RS485 Terminations (JP2)

Jumper JP2 is used to enable 120 Ohm termination for serial port in RS485 and RS422 modes. JP2 will be available in Low Cost Eagle baseboard only.

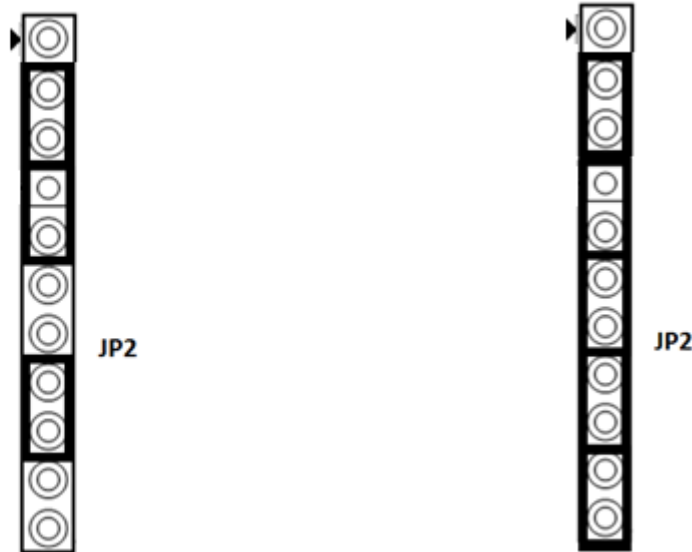

RS-485 Mode Termination Enabled

RS-422 Mode Termination Enabled

Figure 12 Jumper Block JP2

1-2	2-3	USBO1 Mode
In	Out	Peripheral mode
Out	In	Host mode (USB A to A cable should be used)

4-5	6-7	8-9	10-11	Mode
In	Out	In	Out	120 Ohm termination enabled on pairs TX3 and RX3 (For RS-485 Mode)
In	In	In	In	120 Ohm termination enabled on all four pairs (For RS-422 Mode)
Out	Out	Out	Out	Termination Disabled (RS-232 Mode)

Note:

1. Do not install a jumper on 3,4,5-6, 7-8 and 9-10 positions.

9 Getting Started

This section describes the steps needed to get Eagle and Eaglet up and running, and assumes that user also has an Eagle Development Kit or Eagle Cable Kit.

9.1 Development Kit

<i>Model Number</i>	<i>Description</i>
To be Updated	

9.2 Quick Setup

1. Insert the Apalis Module into the MXM connector on the Eaglet: Remove the 2 screws on the mounting spacers. Insert the module at an angle of approximately 45 degrees relative to the board and push in all the way. After the module is properly inserted, press down to seat the module on the two mounting spacers, and fix in place with the 2 screws. Note the middle spacer is intended as a support mechanism to prevent the Apalis module from deflecting when a heat sink is installed over it and pressing down on the processor chip.
2. Attach the required cables. A minimum set generally consists of power, keyboard, mouse, and one of the displays.
3. Attach display, keyboard, and mouse (if needed) to the cables.
4. Connect the jumpers as mentioned in [Jumper Description](#) for a default settings or can be changed as desired by the user.
5. Connect power to power input connector **J7** (OR can be fed through connector J1 and J14 on Panel IO Board if used) to your power supply. The input connector and cable are keyed to prevent incorrect connection.

WARNING: Attaching the power connector incorrectly will damage the board!

WARNING: Be sure the input voltage is within the allowed range for the board. An input voltage exceeding the board's limit will cause serious damage to the board.

6. Connect the debug serial port to a PC using terminals like Teraterm with the below settings.

Debug port details:

Communication: RS232

Serial Port : Port1

Baud rate : 115200

Flow control : None

Stop bits : 1

9.3 Booting

Apalis modules will be booted through on-module eMMC by default.

9.3.1 Updating Software Image from SD card [for systems with U boot available]

Following steps depicts software update on module assuming that module has U-BOOT in it.

1. Preparing SD card

- a. Download image
- b. Unzip the downloaded compressed image. [it is compressed with 7zip]
- c. Flash the SD card with downloaded image.

One can flash SD card as follows:

Get any microSD card of at least 2GB memory or higher. Memory Card storage capacity must be higher than the image size.

Get a USB SD card adapter, insert SD card and connect to PC.

In Windows, get any disk cloning application and flash the SD card with image.

Steps to flash SD card using Win32DiskImager application

- a. Download Win32DiskImager from <https://sourceforge.net/projects/win32diskimager/>
- b. Download and install the 'Win32 Disk Image writer software' from the given link.
- c. Run the Application Win32DiskImager from the start menu.

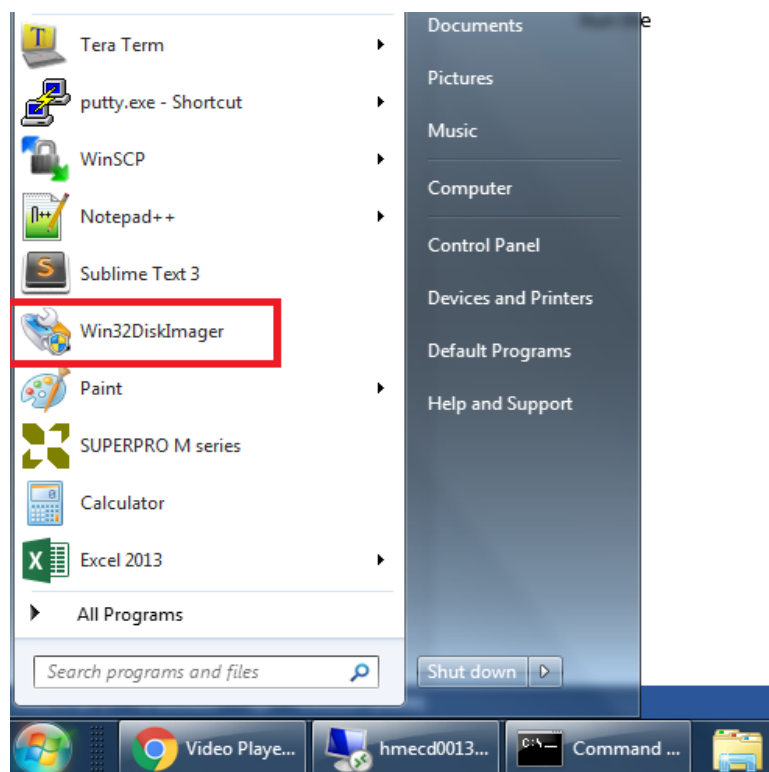

- d. The application is launched.

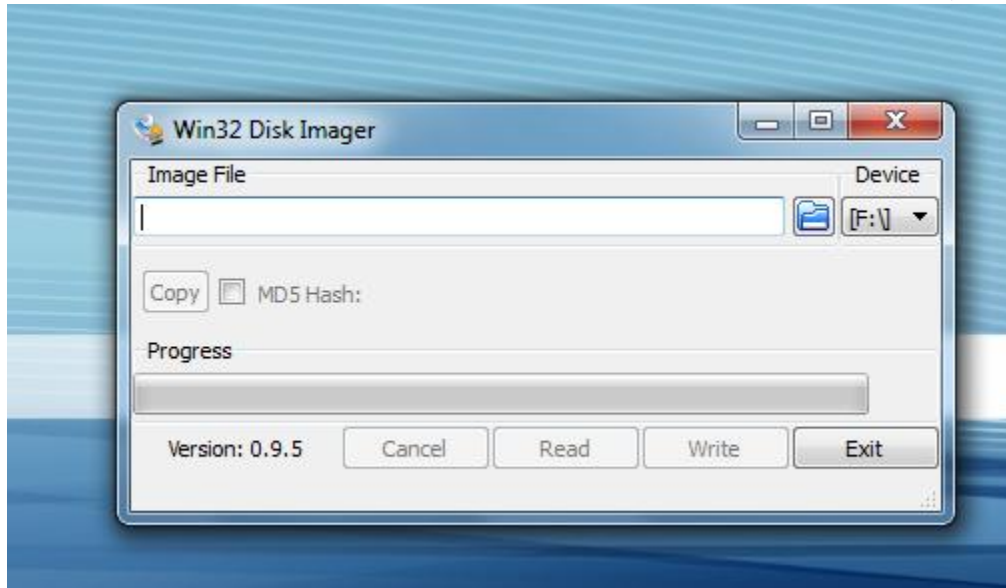

- e. Locate the Linux image - imx_eagle_20170220.img or the latest version received.

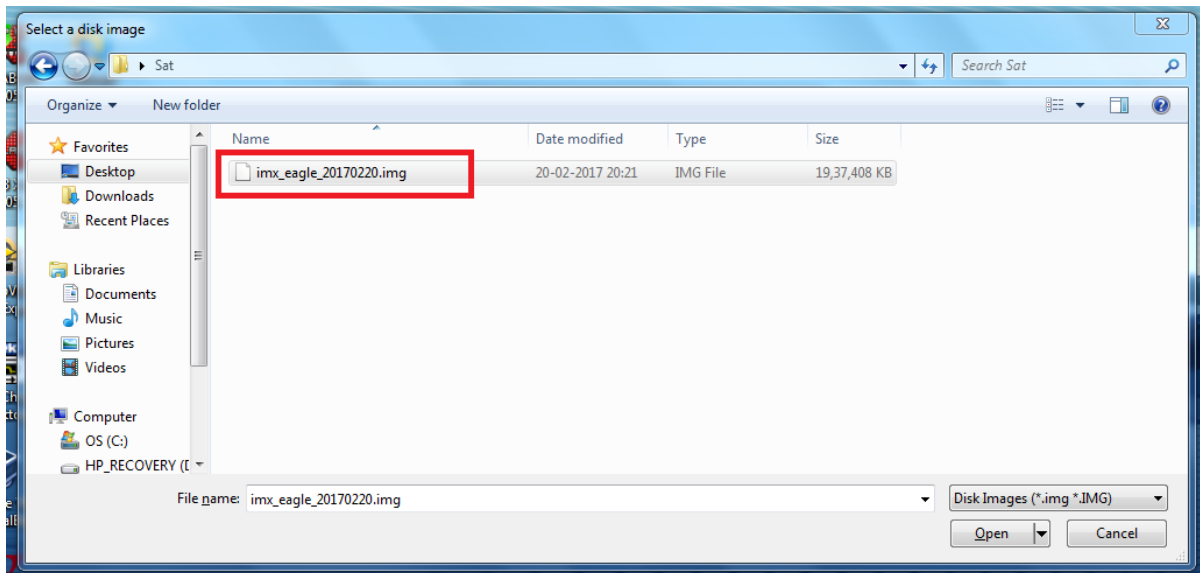

- f. Now the image is ready to flash into SD card or USB

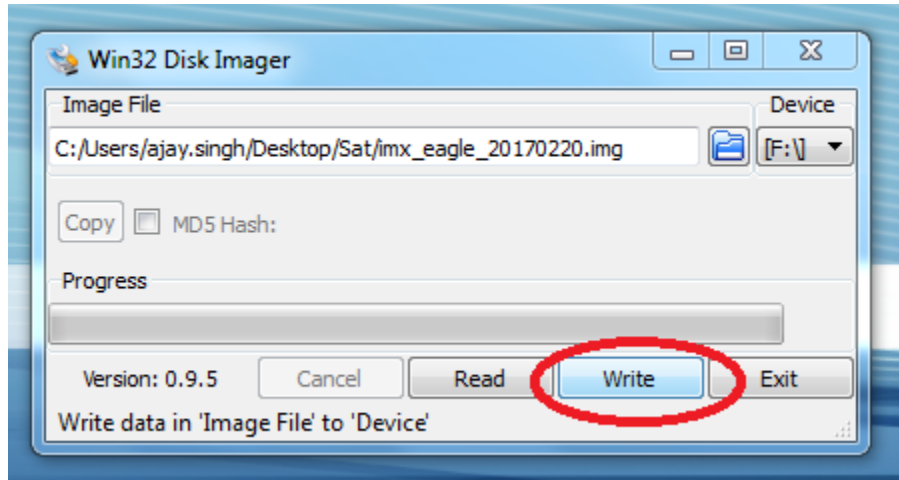

- g. Give Write option and you will be prompted with the following dialog window.



- h. Give Yes to proceed.
i. After image write is completed, you will see the Image write completion successful dialogue window.



- j. Give exit from the application.
k. Now you are ready to go. Take the memory card and insert it to the SD card slot at 'J18' connector location and you are ready to go.

2. Setting up hardware
 - a. Ensure necessary power supply based on the module variant (5V or 9 to 36V).
 - b. Ensure the Debugging serial port (Port1) is connected to external PC
 - c. Initial serial port settings are: baud rate =115200, 8 data bits, No parity and 1 stop bit.
3. Updating image from SD card
 - a. Insert SD card into slot.
 - b. Power on the board.
 - c. Interrupt Uboot by pressing any key.
 - d. Once in Uboot prompt, type 'run setupdate' and press Enter.
 - e. Type 'run update'⁽¹⁾, Enter. This updates image, device tree and rootfs all at once.
 - f. After update, system re boots itself.
 - g. Login with default username and continue. Default username is 'root'.
 - h. Once you entered in Linux, type 'reboot' and press enter. when it reboots, interrupt Uboot by pressing any key. In Uboot prompt type 'env default -a' and enter 'saveenv'.
 - i. Reboot the system by typing 'reset' and allow the board to boot Linux. Login with default user name as explained above.
 - j. Now the board is ready for user⁽²⁾.

Note:

1. For Apalis I.MX6 rev 1.1B version or later version modules the command is different.
Need to type 'run update_it' in case of IT grade modules used.
For Non- IT grade modules need to type 'run update' as usual.
2. After completing the process of software Image update from SD card, the default display is set to HDMI port that supports resolution of 1920x1080. If any other display is used, then refer section [11](#) for commands to set other display ports.

10 Start-up scripts

Start-up script [custom_startup_script.sh] is added along with the image. Start-up script exports the GPIO's. It helps to configure Default states for I2C GPIOs. Start-up configuration script can be found in /etc/init.d/.

Default states for GPIOs available in J24 and J25 are configured using gpioconfig.xml file

gpio-number – gpio number to configure

dir - direction, in or out

val - value, high or low

Refer section 13.4.3 for default GPIO states configured in the release image.

Configure the display interface through U-boot video arguments (Detailed Instruction available in the Toradex links).

Below are some video arguments tested for I.MX6 COM during development for each display interface

For VGA Interface:

```
setenv vidargs 'video=mxcfb0:dev=vdac,1024x768M@50,if=RGB565 video=mxcfb1:off video=mxcfb2:off video=mxcfb3:off fbmem=32M'
```

For HDMI Interface:

```
setenv vidargs 'video=mxcfb0:dev=hdmi,1920x1080M@50,if=RGB24 video=mxcfb1:off video=mxcfb2:off video=mxcfb3:off fbmem=32M'
```

For LVDS Interface:

```
setenv vidargs 'video=mxcfb0:dev=ldb,1920x1080M@50,if=RGB24 video=mxcfb1:off video=mxcfb2:off video=mxcfb3:off fbmem=32M'
```

11 Display Features

Eagle and Eaglet supports HDMI, VGA and LVDS LCD as display device options.

11.1 VGA

VGA display can be set as primary or secondary Display using the “[setenv vidargs](#)” command during boot stage. Maximum VGA resolution is 1280x1024 @ 60Hz. VGA display is supported only in Apalis iMX6. Apalis T30 and TK1 module does not support VGA display output.

For quick reference user may refer the above section ‘some video argument tested for I.MX6 COM during development’ for Uboot commands. User has to edit the resolution value ‘XXXX x XXXXM@50’ in the arguments according to display available with them.

For other Apalis COM modules to enter the arguments refer the above Toradex developer link by clicking on ‘setenv vidargs’.

11.2 HDMI

HDMI display is supported for all the three Apalis modules. Maximum resolution supported by different Apalis modules is as below.

Apalis Module	Maximum Resolution
iMX6	V1.4a,1080p
T30	V1.4a,1080p
TK1	V1.4b, 2160p

11.3 LVDS

LVDS display is supported for all the three Apalis modules. Maximum resolution supported by different Apalis modules are as below.

Apalis Module	Maximum Resolution
iMX6	2x 1366x768x24bpp Single or 1x 1920x1200x24bpp Dual
T30	1x 1280x1024x24bpp Single or 1x 2048x1536x24bpp Dual
TK1	1x 1920x1200x24bpp Single

To set Backlight brightness when using LVDS display:

For I.MX6 COM module:

0% Brightness

```
echo 0 > /sys/class/backlight/backlight.17/brightness
```

100 % Brightness

```
echo 6 > /sys/class/backlight/backlight.17/brightness
```

Note:

- Internal to the T30 module, it serializes the parallel RGB and control signals into differential LVDS pairs. Additional internal GPIOs need to be controlled for setting up the LVDS display when using T30 ARM module. Refer Section 5.5.2 of [T30 datasheet](#) for information.
- GPIO_480 controls the 5V/3V Power enable for LVDS display and it should be enabled for LVDS interface functionality. GPIO_480 is enabled by default through the startup scripts. Refer [GPIO Handling](#) section for more information.
- Make sure 12V power input is fed to Eaglet/Eagle at J7. (Connect 12V at J1 on [Panel IO](#), if used)
- While connecting LVDS display using T30 module, if any screen brightness problem (Dim display) is encountered, make sure the following GPIO's configuration is proper. GPIO No 219, GPIO No 223 should drive logic low state. Refer the link [http://developer.toradex.com/knowledge-base/gpio-\(linux\)](http://developer.toradex.com/knowledge-base/gpio-(linux)) for processor GPIO read/write procedure.

11.3.1 LCD Backlight

The LCD backlight control is provided by a PWM circuit. LCD backlight power and control are on a separate latching connector (**J10**). Duty cycle (Brightness) can be varied as instructed in the link below [http://developer.toradex.com/knowledge-base/backlight-\(linux\)](http://developer.toradex.com/knowledge-base/backlight-(linux))

Refer [LVDS VCC & Backlight \(JP1\)](#) section for jumper configuration details.

11.4 Dual Display

Eagle supports dual display operation i.e.; Multiple displays can be enabled at the same time based on the ARM module support. This feature can be enabled by [setting the environment variables](#) during boot stage. Display can be either extended or duplicated to secondary display.

In T30, dual display can be configured using the options available in Monitor preferences

In iMx6, extended display can be achieved using applications like Cairo to load data on the secondary frame buffer.

Note: In Extended display mode the total resolution of the combined displays should not exceed the maximum resolution supported by the processor

Sample test set up for demonstrating dual display with iMx6:

Dual display feature can be demonstrated using the Cairo Library. Copy the Cairo & sample *.png image to the target device and enter the following command.

```
# ./cairo sample.png
Enter frame buffer number: 2
```

Sample image will be displayed on the secondary display.

NOTE: Before running cairo utility user has to set the appropriate video arguments. For example, to test dual display on VGA and HDMI set the following video argument in Uboot

Note: U boot arguments set manually from U boot prompt may be modified by start-upscripts at boot time. So if someone wants to set these extra u boot parameters permanently, then disable start up scripts.

```
$ setenv vidargs 'video=mxcfb2:dev=vdac,1024x768M@50,if=RGB565
video=mxcfb0:dev=hdmi,1280x1024M@50,if=RGB24 video=mxcfb1:dev=off
video=mxcfb3:dev=off'
$saveenv
```

11.5 USB Interface

Eagle supports 6 USB ports and it is limited based on the Eagle variant and ARM module used. Below table list all the USB ports supported by Eagle variant/ARM Modules.

EAGLET	Panel IO or J12 (2x5 Header)		J17 (USB 3.0 Header)	
Apalis Variant	Port 1	Port 2	Port 3	Port 4
iMx	USBH2 (2.0)	USBH3 (2.0)	OTG_USBH1(2.0)	USBH4(2.0)
T30	USBH2 (2.0)	USBH3 (2.0)	OTG_USBH1(2.0)	Not Available
TK1	USBH2 (2.0)	Not Available	OTG_USBH1(3.0)	USBH4 (3.0)

EAGLE	Panel IO or J12 (2x5 Header)		J17 (USB 3.0 Header)		J16 (2x5 header)	
ARM	Port 1	Port 2	Port 3	Port 4	Port 5	Port 6
iMx	From Hub	USBH3 (2.0)	OTG_USBH1(2.0)	USBH4(2.0)	From Hub	From Hub
T30	From Hub	USBH3 (2.0)	OTG_USBH1(2.0)	Not Available	From Hub	From Hub
TK1	From Hub	Not Available	OTG_USBH1(3.0)	USBH4(3.0)	From Hub	From Hub

Note that, USB3.0 is supported for TK1 module only. With other ARM modules, USB2.0 interface are available on the same USB3.0 header.

In both Eagle and Eaglet variants, Port 3 (USBO1 from ARM module) supports OTG. The port can be either configured as Host or as peripheral using Jumper JP2. Refer USB OTG & RS422/RS485 Terminations (JP2) for more details.

Below figure illustrate the usage of OTG supported port-3 in both Host and Peripheral mode.

Eagle OTG implementation

1. Host mode (Default)

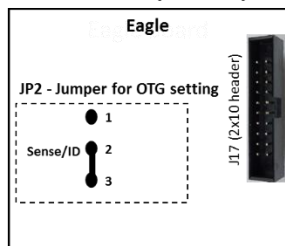

2. Peripheral mode

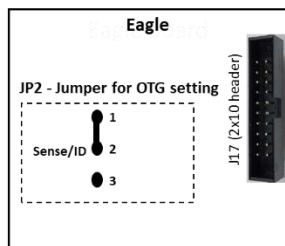

Figure 13 USB OTG Usage

12 Serial Ports and System Console

12.1 Configuration

Eaglet support 4 serial ports (Serial ports 1 to 4) and Eagle supports up to 8 serial ports (Serial ports 1 to 8). Serial ports 5 to 8 are realized using PCIe to UART chip.

For Eaglet, serial ports 1 and 2 supports RS232/422/485 modes and serial ports 3 and 4 supports only RS232 mode.

For Eagle, all the serial ports (1-8) supports RS232/422/485 modes. Mode selection is handled by I2C GPIO expander and all the ports are set in RS232 mode by default. Refer [GPIO Handling](#) section for more information. Serial port multimode functionalities are ARM module dependent due to hardware limitations in the ARM modules.

Below tables illustrates the available Serial modes for each ARM module in Eagle.

ARM Module	Mode	UART1	UART2	UART3	UART4	UART5	UART6	UART7	UART8
iMx6	RS232	Available	Available	Available (TX,RX only)	Available (TX,RX only)	Available	Available	Available	Available
	RS422	Available	Available	Available	Available	Available	Available	Available	Available
	RS485 (Half duplex)	Available	Available	Available	Available	Available	Available	Available	Available
T30	RS232	Available	Available	Available (TX,RX only)	Available (TX,RX only)	Available	Available	Available	Available
	RS422	Available	Available	Available	Available	Available	Available	Available	Available
	RS485 (Half duplex)	Transmit only	Transmit only	Transmit only	Transmit only	Available	Available	Available	Available
TK1	RS232	Available	Available	Available (TX,RX only)	Available (TX,RX only)	Available	Available	Available	Available
	RS422	Available	Available	Available	Available	Available	Available	Available	Available
	RS485 (Half duplex)	To be tested	To be tested	To be tested	To be tested	Available	Available	Available	Available

Configuring Serial ports:

Serial Port configuration includes two steps:

Step 1: Configure the mode – RS232/RS422/RS485.

Mode configuration can be done using I2C GPIOs. Refer section 12.4 for mode configuration details.

Refer [GPIO Handling](#) section for configuring GPIO states

Note: By default, all serial ports are configured for RS232 mode through startup scripts

Step 2: Enable RS485 direction control feature if port is configured for RS422 or RS485 mode.

When the port is used in RS422 and RS485 mode, this RS485 direction control utility should be enabled to control driver enable (DE) and Receiver enable (RE#) of the transceiver chip.

Note: When the serial port is in RS232 mode, RS485 direction control utility should be disabled to ensure RS232 flow control signals operation (RTS, CTS).

Enabling/Disabling RS485/RS422 direction control utility:

RS485_util gives the option to enable/disable RS485/422 direction control on Apalis and Exar UART ports.

Syntax:

```
# rs485_util <space><port_number><space><1/0>
```

Example-1: Enable ttymxc0 for RS485/RS422

```
# rs485_util ttymxc0 1
```

Example-2: Disable ttymxc0 for RS485/RS422

```
# rs485_util ttymxc0 0
```

RS485 Direction control scheme:

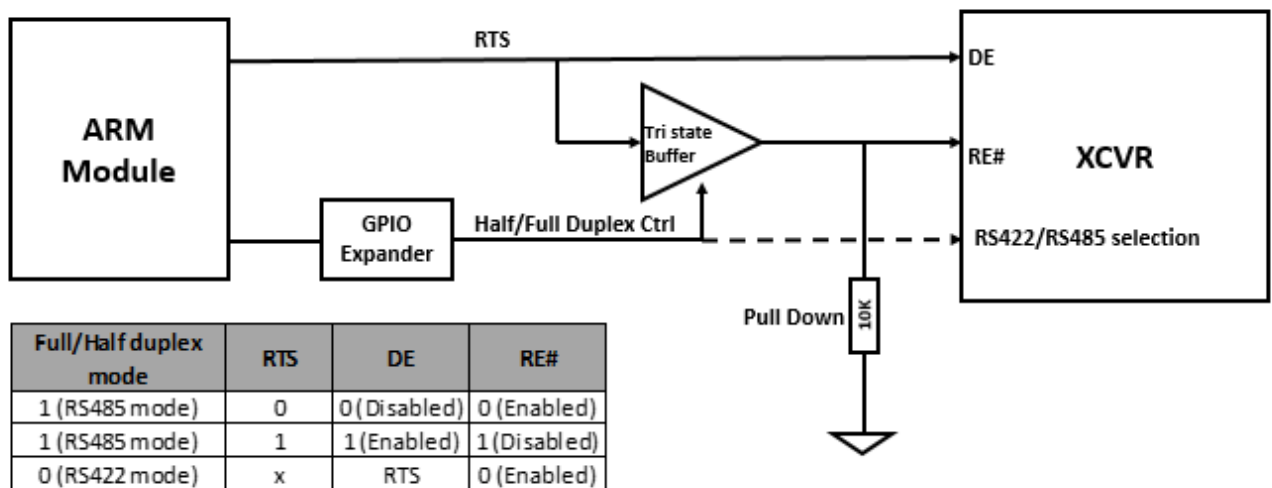

Figure 14 RS-485 direction control hardware implementation

Above figure describes the RS485 direction control implementation in Eagle.

When Port is configured in RS485 mode, both DE and RE# are control by RTS signal.

When Port is configured in RS422 mode, DE is controlled by RTS and RE# is pulled down (enabled) independent of RTS.

In RS485 mode, RS485 direction control utility toggles the RTS line while sending data to enable/disable DE and RE# controls for half duplex communication.

In RS422 mode, although the Receiver is always enabled by pull down, RS485 direction control utility should be enabled for controlling the driver enable (DE).

Note: Due to limitation in T30 ARM module, RTS toggling is not possible in RS485 mode and the RTS line is driven high always by the RS485 direction control utility to ensure transmission. Data reception is not possible in Apalis UARTs (Port 1-4) in RS485 mode with T30 ARM module.

12.2 System Console

In both Eaglet and Eagle baseboard, serial port 1 acts as a console port (J11).

For using port 1 as a normal Serial port, the debug console functionality should be disabled by following the instruction given below

- Power on and Interrupt the Uboot in the debug console.
- Type `setenv console ''` and Enter. This sets the default debug console as none.
- Type `saveenv`, press Enter key.
- Type `reset`, press Enter. This will reboot the board and it's ready to go.

```

U-Boot 2014.04 <Dec 19 2014 - 18:18:44>
CPU: Freescale i.MX6Q rev1.5 at 792 MHz
Reset cause: WDOG
Board: Toradex Apalis iMX6
I2C: ready
DRAM: 1 GiB
PMIC: device id: 0x10, revision id: 0x11
PMIC: programmed
MMC: FSL_SDHC: 0, FSL_SDHC: 1, FSL_SDHC: 2
auto-detected panel HDMI
Display: HDMI <1024x768>
In: serial
Out: serial
Err: serial
Net: using phy at 7
FEC [PRIME]
Hit any key to stop autoboot: 0
Apalis iMX6 #
Apalis iMX6 #
Apalis iMX6 #
Apalis iMX6 #
Apalis iMX6 # setenv console''
Apalis iMX6 # saveenv
Saving Environment to MMC...
Writing to MMC(0)... done
Apalis iMX6 # reset
resetting ...
  
```

Figure 15 Screen shot – Configuring the Console debug port

Same procedure can be used to set port 1 as debug console again.

12.3 Serial port numbers

For Exar ports (Port 5 to 8), without any external serial device connected to the board, the device number detected are as follows

Port Name	Connector	Device Name (iMx6)	Device Name (T30)	Device Name (TK1)
Apalis Port 1	J11	ttymxc0	ttyS0	ttyS0
Apalis Port 2	J11	ttymxc1	ttyHS3	ttyTHS1
Apalis Port 3	J15	ttymxc3	ttyHS1	ttyTHS2
Apalis Port 4	J15	ttymxc4	ttyHS2	ttyTHS3
EXAR Port 5	J21	ttyS0	ttyS1 * ²	ttyS1 * ²
EXAR Port 6	J21	ttyS1	ttyS2 * ²	ttyS2 * ²
EXAR Port 7	J22	ttyS2	ttyS3 * ²	ttyS3 * ²
EXAR Port 8	J22	ttyS3	ttyS4 * ²	ttyS4 * ²

Refer [http://developer.toradex.com/knowledge-base/uart-\(linux\)](http://developer.toradex.com/knowledge-base/uart-(linux)) for additional information on UARTs.

Note:

1. Device name for EXAR Serial ports varies when some add on cards with serial devices are connected to the module.
2. These EXAR Serial ports functionality is not supported in current software version release.

12.4 UART configuration GPIO details for RS232/422/485 modes

12.4.1 Apalis UART ports

GPIO Number	RS232	RS422	RS485
	Value	Value	Value
<i>Apalis UART - 1 (imx6 - ttymxc0, T30-ttyS0, TK1-ttyS0)</i>			
496	Low	High	High
497	Low	Low	High
498	Low	High	High
499	Low	High	Low
<i>Apalis UART - 2 (imx6 - ttymxc1, T30-ttyHS3, TK1-ttyTHS1)</i>			
500	Low	High	High
501	Low	Low	High
502	Low	High	High
503	Low	High	Low
<i>Apalis UART - 3 (imx6 - ttymxc3, T30-ttyHS1, TK1-ttyTHS2)</i>			
504	Low	High	High
505	Low	Low	High
506	Low	High	High
507	Low	High	Low
<i>Apalis UART - 4 (imx6 - ttymxc4, T30-ttyHS2, TK1-ttyTHS3)</i>			
508	Low	High	High
509	Low	Low	High
510	Low	High	High
511	Low	High	Low

12.4.2 Exar UART Ports

Pin Number	RS232	RS422	RS485
	Value	Value	Value
<i>EXAR UART - 5 (imx6 - ttyS0, T30-ttyS1, TK1-ttyS1)</i>			
464	Low	High	High
465	Low	High	Low
466	Low	High	High
467	Low	Low	High
<i>EXAR UART - 6 (imx6 - ttyS1, T30-ttyS2, TK1-ttyS2)</i>			
468	Low	High	High
469	Low	High	Low
470	Low	High	High
471	Low	Low	High
<i>EXAR UART - 7 (imx6 - ttyS2, T30-ttyS3, TK1-ttyS3)</i>			
472	Low	High	High
473	Low	Low	High
474	Low	High	High
475	Low	High	Low
<i>EXAR UART - 8 (imx6 - ttyS3, T30-ttyS4, TK1-ttyS4)</i>			
476	Low	Low	High
477	Low	High	High
478	Low	High	Low
479	Low	High	High

13 Utility connector features

13.1 I2C and PWM

Eagle and Eaglet features 14 pin utility connector where 3 PWM signal, 1x SPI, 1x I2C, 1xGPIO (3.3V) and S/PDIF interface can be accessed. Refer [IO Connector details](#) section for more information.

14 DAQ Architecture overview

Eagle and Eaglet supports different provisions for Data Acquisition in the form of Analog input, GPIOs, Opto isolated IOs etc.

14.1 Analog input

Eagle and Eaglet supports 4 singled ended analog inputs. A/D section resides in Apalis module and has following features.

- 12-bit ADC
- Conversion rate up to 180KS/s for iMX and T30 module
- Conversion rate up to 818KS/s for TK1 module
- Input voltage range: 0V to 3.3V
- Absolute maximum input of +3.5V

For details, please refer to [http://developer.toradex.com/knowledge-base/adc-\(linux\)](http://developer.toradex.com/knowledge-base/adc-(linux))

14.2 PWM

Eagle and Eaglet features four general purpose PWM outputs (3.3V) directly coming from Apalis module. For T30 and TK1 Apalis Module, the duty cycle has an 8-bit resolution. The maximum output frequency is 187.5 kHz.

For iMX6 module the duty cycle has an 8-bit resolution.

For details, please refer to [http://developer.toradex.com/knowledge-base/pwm-\(linux\)](http://developer.toradex.com/knowledge-base/pwm-(linux))

14.3 GPIO

14.3.1 GPIOs form Apalis Module

Eagle and Eaglet supports eight GPIOs (3.3V). The GPIO direction and state can be software controlled.

For details, please refer to [http://developer.toradex.com/knowledge-base/gpio-\(linux\)](http://developer.toradex.com/knowledge-base/gpio-(linux))

Alpha numeric mapping for GPIOs are available along with the connector pinouts. Please refer GPIOs (J6)

14.3.2 GPIOs using I2C GPIO expander

Eagle and Eaglet supports I2C GPIO expander to realize the GPIOs for user access, UART mode controlling and others. Alpha numeric mapping for GPIOs are available along with the connector pinouts. Please refer _Opto GPIO (J24) and GPIO Header (J25) pinout details.

14.3.2.1 User GPIOs

Eagle supports 8x GPIOs (3.3V) realized using I2C GPIO expander and are available on 2x5 header **J25**.

These IOs are not available on low cost Eaglet. Refer [GPIO Handling](#) section for configuring GPIO states

14.3.2.2 Opto-isolated GPIOs

Eagle supports 4x Opto isolated inputs and 4x Opto isolated outputs available at **J24**. Following table provides Electrical characteristics of opto-isolated inputs and outputs. Refer [GPIO Handling](#) section for configuring GPIO states

Isolated Digital Input:

4x Opto isolated inputs are supported at J5. Following table provides the DC characteristics of the Opto-isolated inputs.

Parameter	Min	Typ	Max
Isolated Digital Input VIL	0V		1.6V
Isolated Digital Input VIH	2.3V		28V
Isolated Digital Input Current	1mA	2.8mA	3.3mA

Isolated Digital Output:

4x Opto isolated outputs are available on J5. Opto isolated outputs are open collector outputs. External 4.75K pull-up to V_OPTO is provided. V_OPTO supply for pull-ups should be given externally. Refer [Opto GPIO \(J5\)](#) for pinout details.

Opto-isolated output characteristics are based on V_OPTO supply voltage.

Note: V_OPTO maximum supply voltage should not exceed 40V

Opto isolated GPIOs are not available on low cost Eaglet

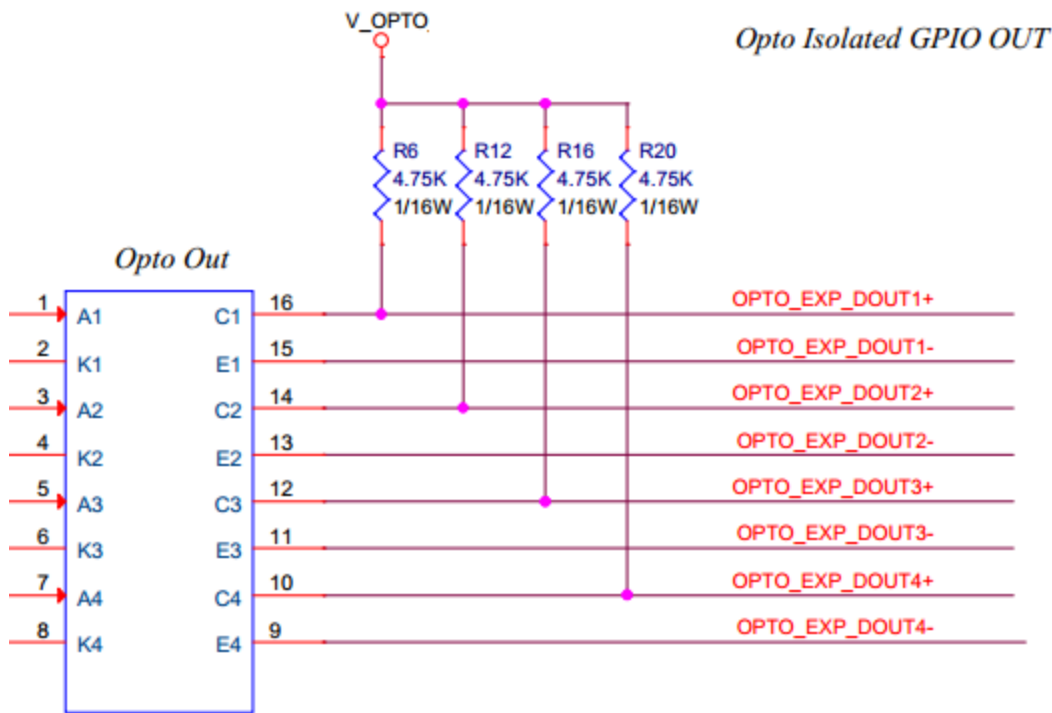

Figure 16 Opto isolated outputs hardware implementation

Note: For Isolated GPIOs, directions are configured by default (4 GPIOs as Inputs and 4GPIOs as outputs compatible for the isolation circuitry) and should not be reconfigured/changed using the GPIO configuration utility.

14.3.2.3 GPIO Handling

Following section provides the set of commands available to control the GPIOs available from I2C GPIO expander.

GPIO Utility is provided with the image file. User can use these utility to access GPIO's

GPIO Set Direction (setdir)

This command sets the direction for specified GPIO.

```
# gpio_util<space>setdir<space><pin_number><space><direction>
```

Please refer **14.3.2.4 List of I2C GPIOs** for valid GPIO numbers. Direction should be either “in” or “out”

GPIO Set Value (setval)

This command sets the value (state) for specified GPIO.

```
# gpio_util<space>setval<space><pin_number><space><state>
```

Please refer **14.3.2.4 List of I2C GPIOs** for valid GPIO numbers. Value should be either “high” or “low”

GPIO Get Direction (getdir)

This command reads the set direction of specified GPIO

```
# gpio_util<space>getdir<space><pin_number>
```

GPIO Get Value (getval)

This command reads the state of specified GPIO

```
# gpio_util<space>getval<space><pin_number>
```

Refer Section - **19.1** for GPIO Library API

Below Table provides valid arguments for “direction” and “state”.

Function	Argument	Comments
Direction	out	Sets GPIO as output
	in	Sets GPIO as output
State	high	Sets GPIO as High (1)
	low	Sets GPIO as Low (0)

Arguments other than mentioned above will not be considered and the command gives back error.

14.3.2.4 List of I2C GPIOs

Below Table provides the details about all the GPIOs available

GPIO Signal Name	Default Direction	GPIO Number	Default state	Purpose
UART PORT 1 CONTROL				
UART_PORT1485/232-	Output	496	Low	UART Port 1 RS485 or RS232 Mode select
UART_PORT1HALF/FULL-	Output	497	Low	UART Port 1 Half/Full duplex enable
UART_PORT1TERM	Output	498	Low	UART Port 1 Full duplex termination enable
UART_PORT1FDTX	Output	499	Low	UART Port 1 Full duplex Driver termination
UART PORT 2 CONTROL				
UART_PORT2485/232-	Output	500	Low	UART Port 2 RS485 or RS232 Mode select
UART_PORT2HALF/FULL-	Output	501	Low	UART Port 2 Half/Full duplex enable
UART_PORT2TERM	Output	502	Low	UART Port 2 Full duplex termination enable
UART_PORT2FDTX	Output	503	Low	UART Port 2 Full duplex Driver termination
UART PORT 3 CONTROL				
UART_PORT3485/232-	Output	504	Low	UART Port 3 RS485 or RS232 Mode select
UART_PORT3HALF/FULL-	Output	505	Low	UART Port 3 Half/Full duplex enable
UART_PORT3TERM	Output	506	Low	UART Port 3 Full duplex termination enable
UART_PORT3FDTX	Output	507	Low	UART Port 3 Full duplex Driver termination
UART PORT 4 CONTROL				
UART_PORT4485/232-	Output	508	Low	UART Port 4 RS485 or RS232 Mode select
UART_PORT4HALF/FULL-	Output	509	Low	UART Port 4 Half/Full duplex enable
UART_PORT4TERM	Output	510	Low	UART Port 4 Full duplex termination enable
UART_PORT4FDTX	Output	511	Low	UART Port 4 Full duplex Driver termination
LCD VOLTAGE ENABLE				
LCD_VDD_EN	Output	480	High	Enable signal for LVDS Power
UART CONFIGURATION DETECT				
CONFIG_UART	Input	481	-	UART Configuration Indicator
SIM CARD DETECT				
SIM_CD	Input	482	-	Micro SIM card detect signal
CAN GPIOs				
CAN_GPIO1	Input	484	-	CAN Module GPIO1
CAN_GPIO2	Input	485	-	CAN Module GPIO2
CAN_GPIO3	Input	486	-	CAN Module GPIO3
AUXILIARY GPIO				
AUX_GPIO0_7	Input	487	-	Auxiliary Connector GPIO
UART PORT 5 CONTROL				
UART_PORT5TERM	Output	464	Low	UART Port 5 Full duplex termination enable
UART_PORT5FDTX	Output	465	Low	UART Port 5 Full duplex Driver termination
UART_PORT5485/232-	Output	466	Low	UART Port 5 RS485 or RS232 Mode select

UART_PORT5HALF/FULL-	Output	467	Low	UART Port 5 Half/Full duplex enable
UART PORT 6 CONTROL				
UART_PORT6TERM	Output	468	Low	UART Port 6 Full duplex termination enable
UART_PORT6FDTX	Output	469	Low	UART Port 6 Full duplex Driver termination
UART_PORT6485/232-	Output	470	Low	UART Port 6 RS485 or RS232 Mode select
UART_PORT6HALF/FULL-	Output	471	Low	UART Port 6 Half/Full duplex enable
UART PORT 7 CONTROL				
UART_PORT7485/232-	Output	472	Low	UART Port 7 RS485 or RS232 Mode select
UART_PORT7HALF/FULL-	Output	473	Low	UART Port 7 Half/Full duplex enable
UART_PORT7TERM	Output	474	Low	UART Port 7 Full duplex termination enable
UART_PORT7FDTX	Output	475	Low	UART Port 7 Full duplex Driver termination
UART PORT 8 CONTROL				
UART_PORT8HALF/FULL-	Output	476	Low	UART Port 8 Half/Full duplex enable
UART_PORT8485/232-	Output	477	Low	UART Port 8 RS485 or RS232 Mode select
UART_PORT8FDTX	Output	478	Low	UART Port 8 Full duplex Driver termination
UART_PORT8TERM	Output	479	Low	UART Port 8 Full duplex termination enable
OPTO GPIOs				
I2C_EXP_DIN1	Input	448	-	Opto/ GPIO Input 1 – J24-3,11
I2C_EXP_DIN2	Input	449	-	Opto/ GPIO Input 2 – J24-4,12
I2C_EXP_DIN3	Input	450	-	Opto/ GPIO Input 3 – J24-5,13
I2C_EXP_DIN4	Input	451	-	Opto/ GPIO Input 4 – J24-6,14
I2C_EXP_DOUT1	Output	452	High	Opto/ GPIO Output 1 – J24-7,15
I2C_EXP_DOUT2	Output	453	High	Opto/ GPIO Output 2 – J24-8,16
I2C_EXP_DOUT3	Output	454	High	Opto/ GPIO Output 3 – J24-9,17
I2C_EXP_DOUT4	Output	455	High	Opto/ GPIO Output 4 – J24-10,18
EXPANDER GPIOs				
EXP_GPIO1_0	Input	456	-	GPIO Header IO 0 - J25-1
EXP_GPIO1_1	Input	457	-	GPIO Header IO 1 - J25-2
EXP_GPIO1_2	Input	458	-	GPIO Header IO 2 - J25-3
EXP_GPIO1_3	Input	459	-	GPIO Header IO 3 - J25-4
EXP_GPIO1_4	Input	460	-	GPIO Header IO 4 - J25-5
EXP_GPIO1_5	Input	461	-	GPIO Header IO 5 - J25-6
EXP_GPIO1_6	Input	462	-	GPIO Header IO 6 - J25-7
EXP_GPIO1_7	Input	463	-	GPIO Header IO 7 - J25-8

15 Type-specific I/O Expansion

The Apalis form factor designates a group of pins on the connector for signals that vary from module to module. This enables the Apalis form factor to accommodate new features on new processors that were not available on prior modules or accounted for in the common module pinout. These signals are brought out to a connector J27 on the Eagle full-size board to give the user access to them. A custom daughterboard may be installed on J27 and fixed in place using the mounting hole provided on the board. The pinout of this connector is shown on page xxx. The definitions of the type specific pins for each module may be found in that module's user manual.

Board connector:

Mating connector for daughterboard:

Type specific daughterboard mechanical dimensions:

16 Programming I2C

Apalis modules support 3 I2C master interfaces.

The following table provides details about the various devices available on the Eagle and Eaglet baseboard.

I2C Master	Slave Device	Slave Address (7bit)
I2C1	PCA9535PW (GPIOs)	21h
	PCA9535PW UART port 5-8 control)	22h
	PCA9535PW (CONFIG, LCD_EN, SIM etc.)	23h
	PCA9535PW (UART port 1-4 control)	24h
	PI7C9X2G404 (PCIe Switch)	68h
I2C2	HDMI	-
	VGA (Optional-Not connected)	-
	LVDS Display	-
I2C3	CSI (1.8V)	-

Please refer to [http://developer.toradex.com/knowledge-base/i2c-\(linux\)](http://developer.toradex.com/knowledge-base/i2c-(linux)) for more details on I2C handling for Apalis.

17 Factory reset and Recovering MAC address

Eagle module has two Ethernet interfaces, one directly from the ARM module and the other through i210 Ethernet controller. The first Ethernet interface from ARM modules carries the unique MAC address given by Toradex. MAC address for the second port are programmed during manufacturing test through U Boot argument.

If a reset of U boot arguments happens, all arguments modified over time will be lost and default arguments as shipped from Toradex will be present. Meaning, the MAC address for the second Ethernet port on the carrier card also will be lost. In such a case, user can check for MAC address present on the product sticker and recover it by entering the same in U boot arguments.

```

COM43:115200baud - Tera Term VT
File Edit Setup Control Window Help

resetting ...

U-Boot 2015.04+fslc+ge1a48b2 <Mar 31 2016 - 01:27:13>

CPU: Freescale i.MX6Q rev1.5 at 792 MHz
CPU: Temperature 47 C
Reset cause: WDOG
I2C: ready
DRAM: 1 GiB
PMIC: device id: 0x10, revision id: 0x11
PMIC: programmed
MMC: FSL_SDHC: 0, FSL_SDHC: 1, FSL_SDHC: 2
auto-detected panel vga-rgb
Display: vga-rgb (640x480)
In: serial
Out: serial
Err: serial
Model: Toradex Apalis iMX6 Quad 1GB U1.1A, Serial# 04843150
Net: using PHY at 7
FEC [PRIME]
Normal Boot
Hit any key to stop autoboot: 0
Apalis iMX6 #
Apalis iMX6 #
Apalis iMX6 # setenv eth1addr '00:14:2d:78:ad:90'
Apalis iMX6 #
Apalis iMX6 # saveenv
Saving Environment to MMC...
Writing to MMC(0)... done
Apalis iMX6 #
Apalis iMX6 # reset

```

Figure 17 Screen shot – Recovering the MAC address for Eth-2 by updating UBoot arguement

18 Panel IO

Eagle and Eaglet supports an add-on board, which connects to the headers available on the bottom edge of the board (orientation with Apalis module on Top edge.). Panel IO board supports the standard connectors for the following interfaces terminated at dual row 2mm header on Eagle/Eaglet baseboard.

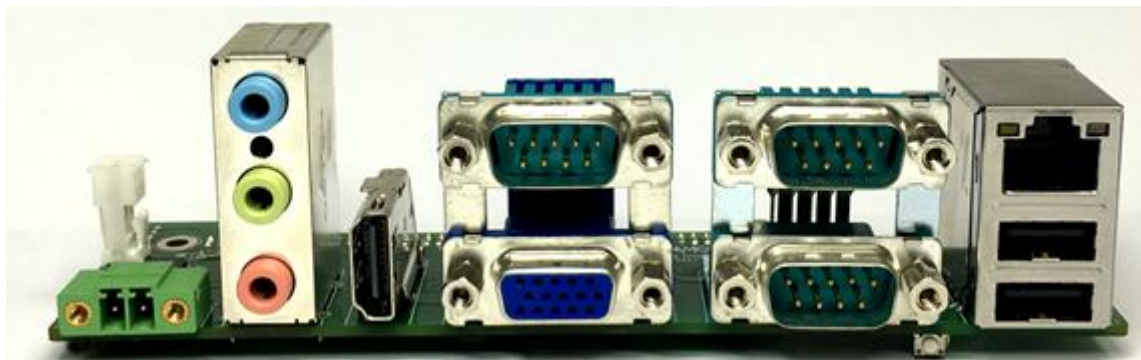

Figure 18 Panel IO board Front View

Below block diagram shows the connection between Eagle and Panel IO.

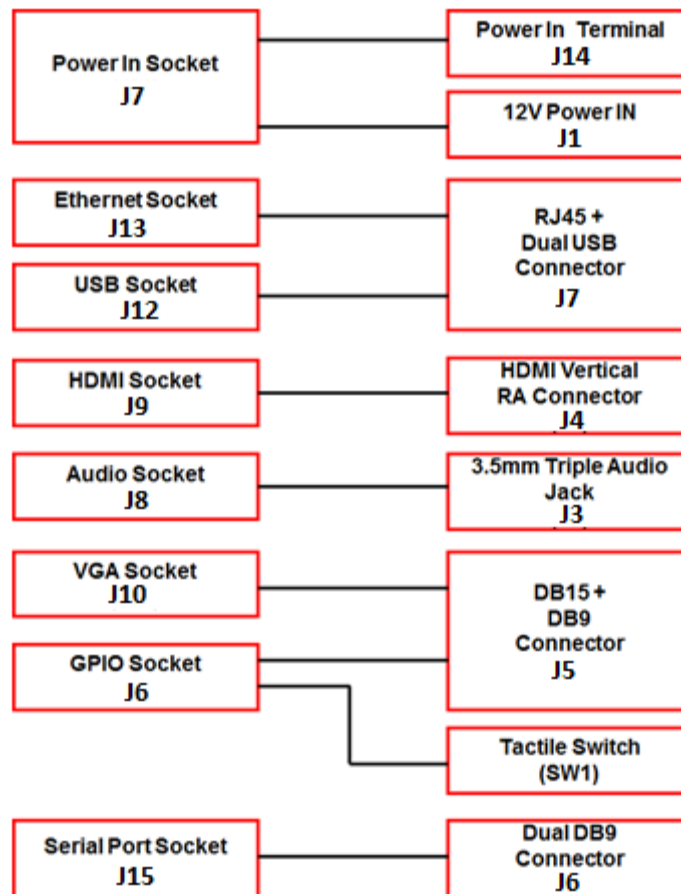

Figure 19 Panel IO to Eagle Connection

19 CAN Add-on Module

Eagle and Eaglet supports 2x CAN ports realized by mounting a CAN Mezzanine module on 2x10 header (**J14**). 2x CAN interface from Apalis module is directly routed to 20 pin Header on Eaglet/Eagle baseboard, along with 1x I2C and 1x SPI interface for general use. CAN transceivers are available on the CAN Add-on module. Below block diagram provides the details about the CAN add-on module.

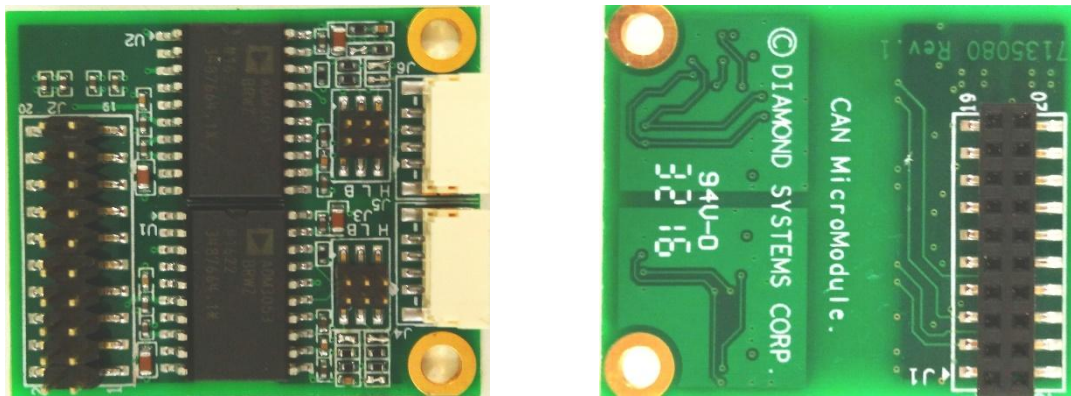
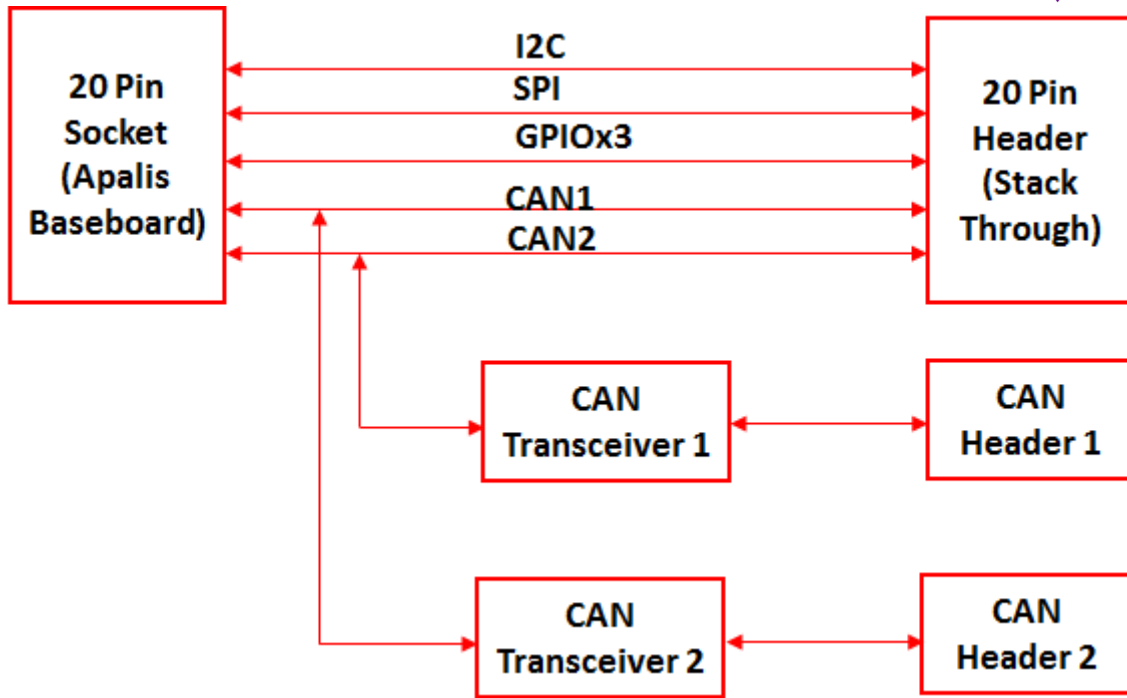

Figure 20 DS-MPE-CAN2L Front view (on left), rear view (on right)

Refer [CAN Header](#) section for pinout description.

19.1 GPIO LIBRARY API

We have 4 functions to set/get pin direction/value as follows.

set GPIO direction:

```
/**
 * Function to set gpio pin direction
 * @name DSC_Eagle_PCA9535_PinDirSet
 * @param1 gpio number
 * @param2 direction, in or out
 * @return status, eSuccess, eInvalidParam, eFailure
 */
eStatus DSC_Eagle_PCA9535_PinDirSet(U16 gpio_no, Gpio_Direction direction);
```

get gpio direction:

```
/**
 * Function to get gpio pin direction
 * @name DSC_Eagle_PCA9535_PinDirGet
 * @param1 gpio number
 * @param2 pointer to direction variable
 * @return status, eSuccess, eInvalidParam, eFailure
 */
eStatus DSC_Eagle_PCA9535_PinDirGet(U16 gpio_no, Gpio_Direction *direction);
```

set gpio State:

```
/**
 * Function to set gpio pin state
 * @name DSC_Eagle_PCA9535_PinStateSet
 * @param1 gpio number
 * @param2 state, high or low
 * @return status, pass or fail
 */
eStatus DSC_Eagle_PCA9535_PinStateSet(U16 gpio_no, Gpio_State state);
```

get gpio state:

```
/**
 * Function to get gpio pin state
 * @name DSC_Eagle_PCA9535_PinStateGet
 * @param1 gpio number
 * @param2 pointer to state variable
 * @return eSuccess, eInvalidParam, eFailure
 */
eStatus DSC_Eagle_PCA9535_PinStateGet(U16 gpio_no, Gpio_State *state);
```

Enumerated data types to use as input to above functions:

```
/* Enumerations */
typedef enum {
    GpioDirectionOut = 0,
    GpioDirectionIn
} Gpio_Direction;

typedef enum {
    GpioStateLow = 0,
    GpioStateHigh
} Gpio_State;

typedef enum {
    eSuccess = 0,
    eInvalidParam,
    eFailure,
    eError
} eStatus;
```

20 Appendix

20.1 Appendix – 1 Compiling Custom Applications

To develop custom application, one need to install cross compiling tool chain as explained in Toradex website. <http://developer.toradex.com/knowledge-base/build-u-boot-and-linux-kernel-from-source-code#Toolchain>

Then compile application and copy executable to board by any means suitable, by USB flash drive, ftp etc. After giving file permissions to these added applications, they can be executed.

Example

```
# arm-linux-gnueabi-gcc <space> <filename1.c> <filename2.c> <space> -o <space> <outputfilename>
```

20.2 Appendix – 2 Inserting COM Module

Assembly must be done very carefully since putting the heatsink in a wrong way will damage the Apalis module or may prevent the system from working properly. The illustration shown below represents how to attach the heatsink solution.

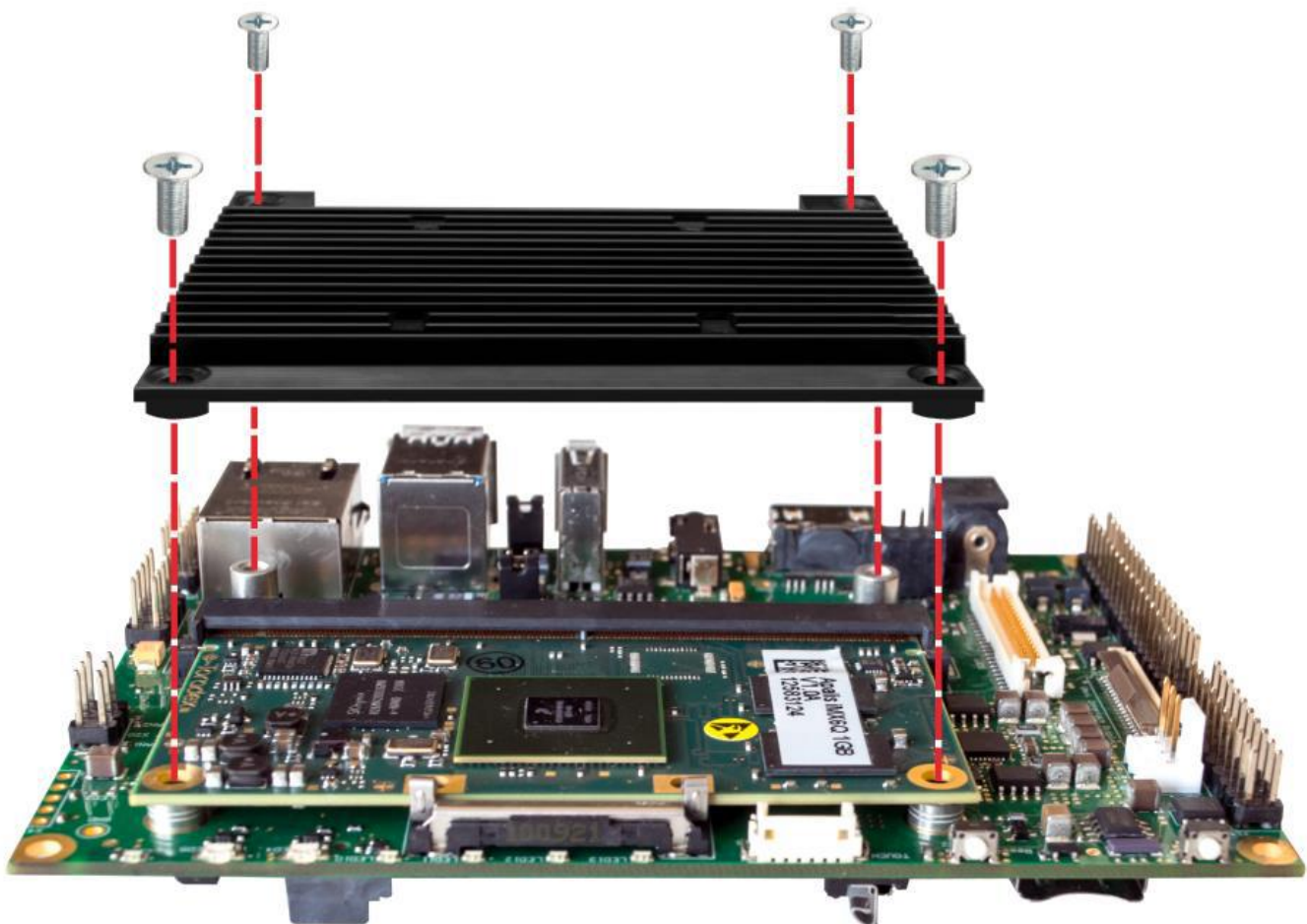

Figure 21 Apalis Heatsink Assembly

20.2.1 Assembly procedure

The following procedure demonstrates how to attach the Apalis heatsink to the Apalis module to complete the heatsink solution. Please read the procedure very carefully to ensure that the module does not get damaged. Necessary precautions should be taken to avoid the electrostatic charges.

1. Clean the processor's top surface using an anti-static cloth.
2. Insert the Apalis module in the MXM socket X1 on the Apalis carrier board.
3. Carefully remove the plastic foil from the TIM.



Figure 22 Remove plastic foil from the TIM

4. Carefully align the mounting holes {1}, {2}, {3}, and {4} on the heatsink to be in-line with fasteners available on the Apalis carrier board. Place the heatsink on the system.



Figure 23 Align heatsink screw holes with the fasteners

5. Use 4 units of M3 sized screws to affix the heatsink together with the system.

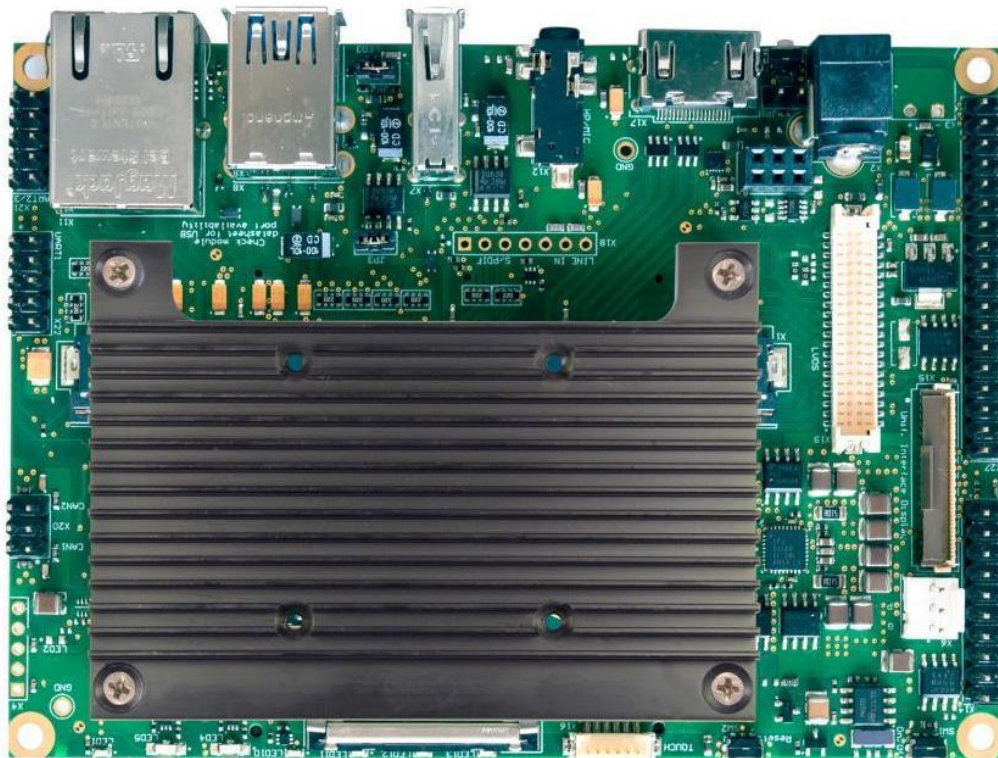

Figure 24 Affix heatsink with the system using M3 sized screws

6. Done. The system is now ready for use.

7. For application which results in the prolonged overheating of the processor, either due to environmental condition (like higher ambient temperature) or due to very high computational power; the DC fan can be mounted on the top of the Apalis heatsink using 2.5m screws (4 units).
8. For the majority of the end applications, an additional heatsink fan will not be required.